

## R2 Roller Installation Manual

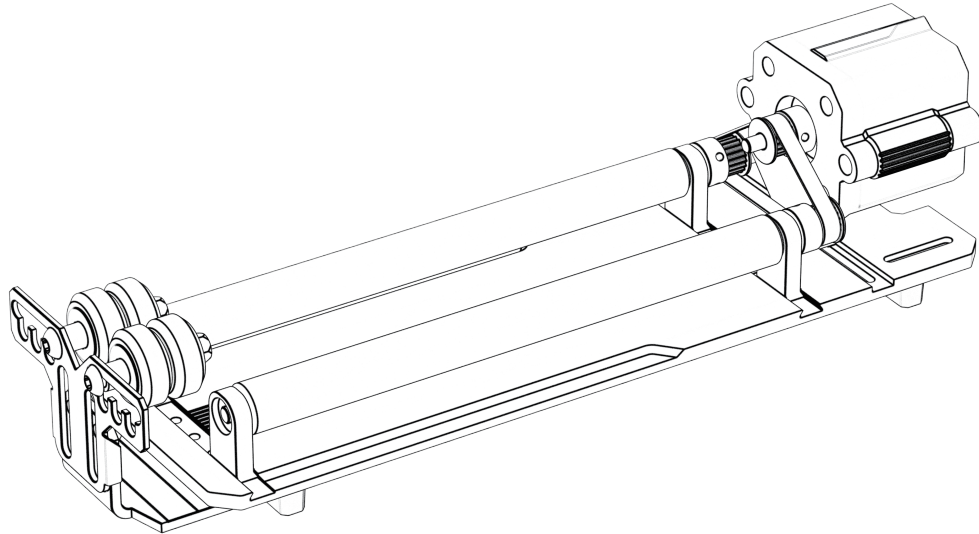

Note: The picture is for reference only, subject to the real thing.  
Please scan the two-dimensional code for more information.

# Packing List

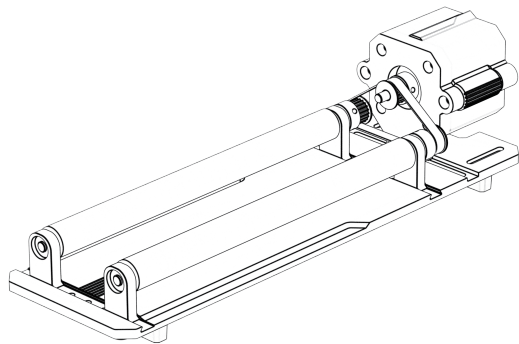

Roller body\*1Pcs

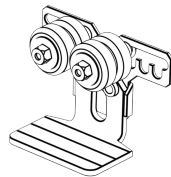

Bracket\*1Pcs



Heightened feet \*4PCS



Sequence line\*1Pcs



Reverse sequence line\*1Pcs

# Installation Guide

## Step 1: Roller

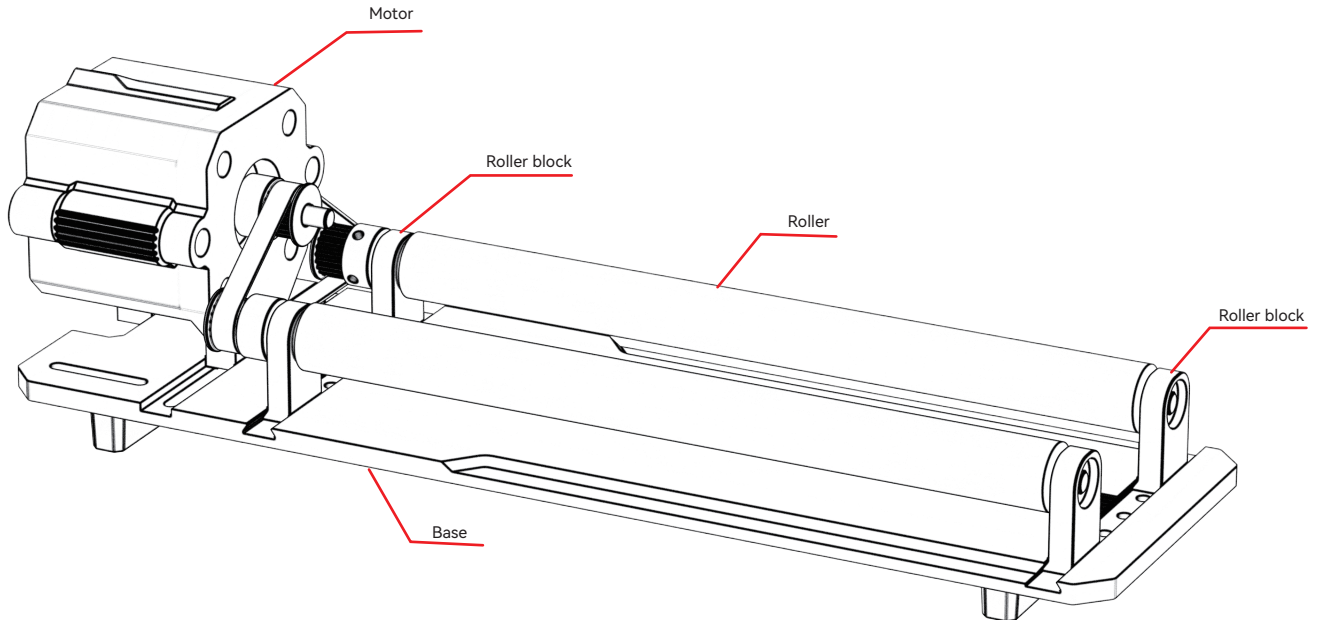

# Installation Guide

Step 2: Choose different gears to install according to the engraved items

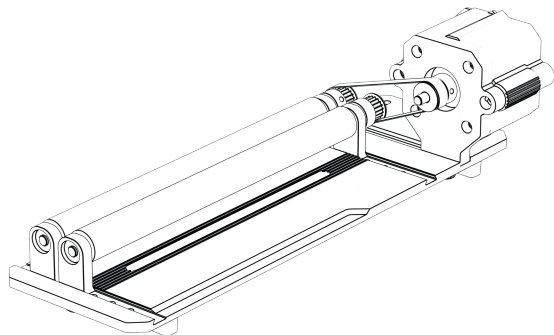

Gear 1:  $10\text{mm} \leq d \leq 20\text{mm}$

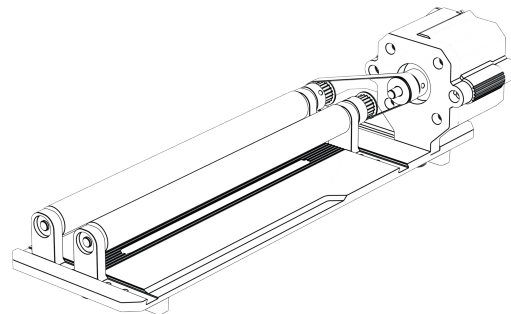

Gear 2:  $30\text{mm} \leq d \leq 40\text{mm}$

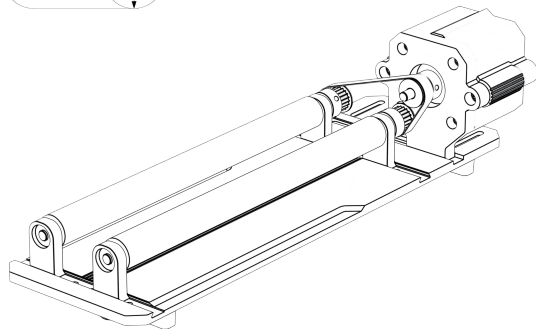

Gear 3:  $40\text{mm} \leq d \leq 50\text{mm}$

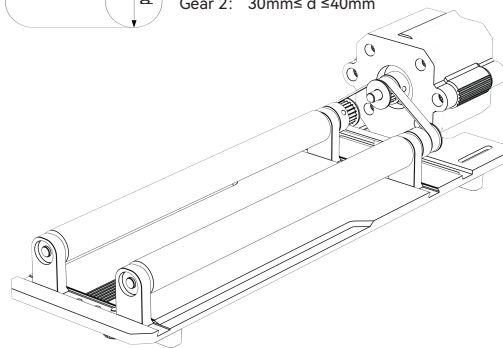

Gear 4:  $50\text{mm} \leq d \leq 80\text{mm}$

# Installation Guide

## Step 3: Adjust Gear

3.1 Select different gears according to the engraved items.

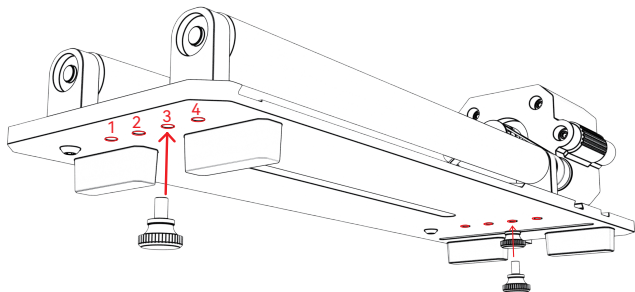

3.2 Move the roller to the appropriate gear and tighten the screw.

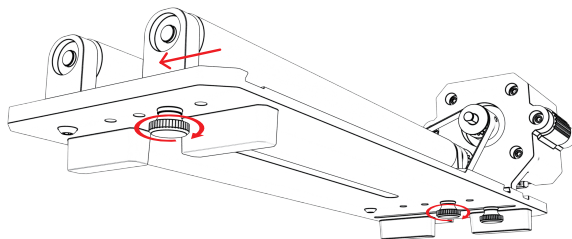

3.3 Move the motor to tighten the belt and tighten the screws at the bottom of the motor.

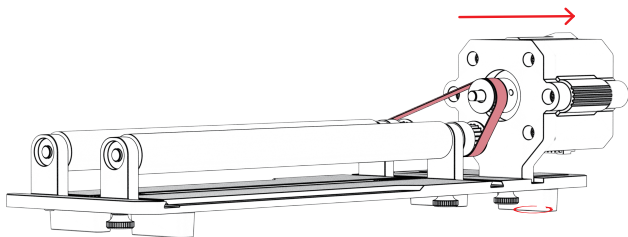

3.4 Adjust the bracket installation: choose different gears according to the engraved special-shaped items, and move the bracket to a suitable position.

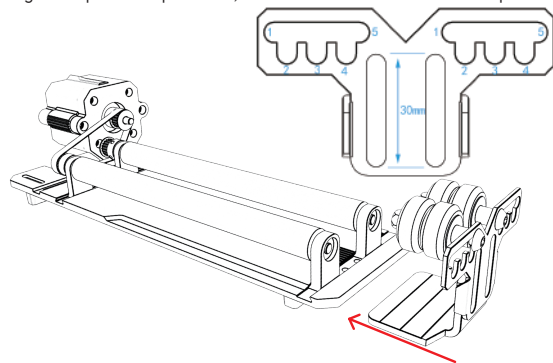

# Installation Guide

## Step 4: Wiring Instructions

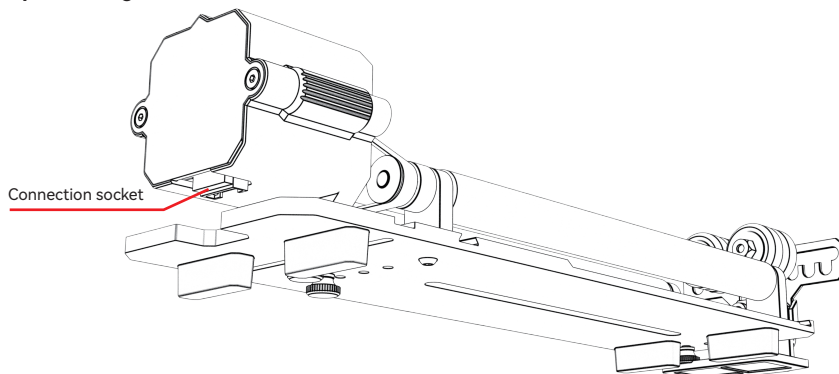

Y-axis motor cable plug



White plug wire

Y-axis motor cable plug



Black plug wire

The roller has two connecting wires, the black plug and the white plug, please note that their wiring sequence is different and you need to connect carefully.

The 4PIN white plug wire is used to connect ATOMSTACK laser engraving machine.

The 4PIN black plug wire is used to connect the third-party laser engraving machine.

The roller kit supports ATOMSTACK and third-party laser cutters and engravers. You need to connect it to the device and use the corresponding software to operate it. If it cannot be connected, please change the order of the wires, and the change process is shown in Figure 1.1-1.2.

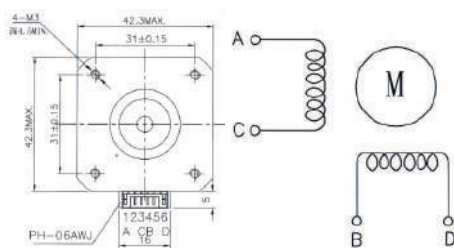

1.1 Connection sequence of white plug wire

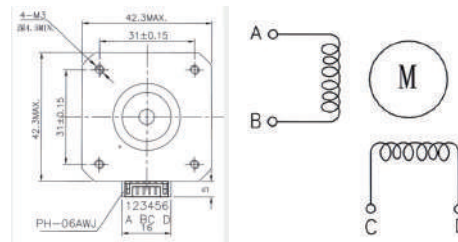

1.2 Connection sequence of black plug wire

# Use LightBurn

## 1. Add "Enable Rotary" to main window

1.1 Click "Settings" on the toolbar

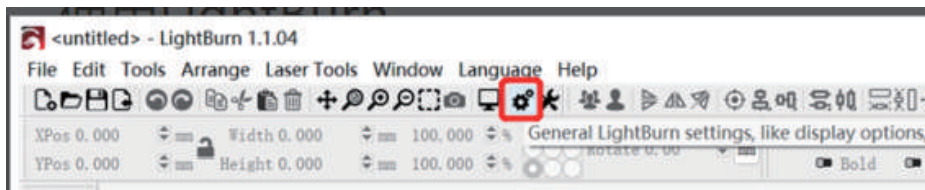

1.2 In the settings window, turn on the "Show rotary enable on main window" button, and click OK.

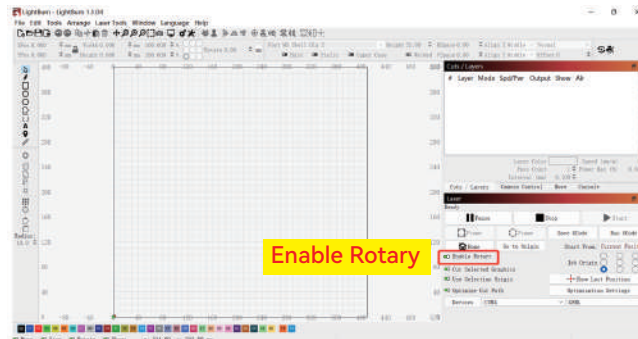
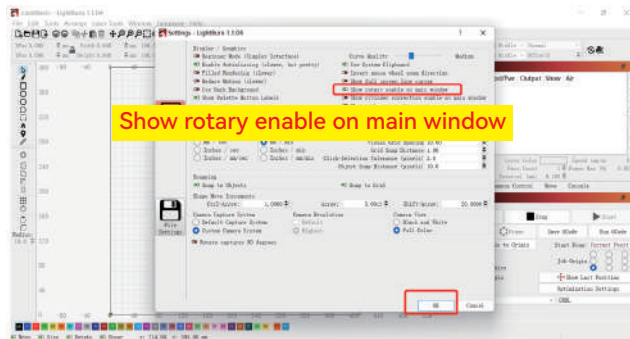

# Use LightBurn

## 2. Open the Rotary Setup window and set the parameters

2.1 Open the Rotary Setup window: Click "Laser Tools" on the toolbar and then click "Rotary Setup"

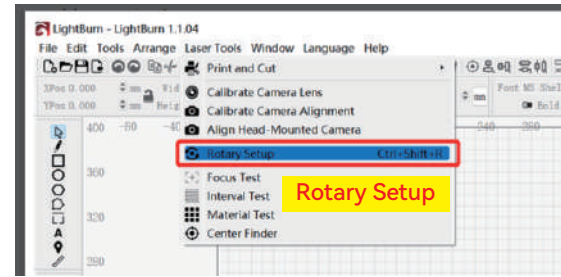
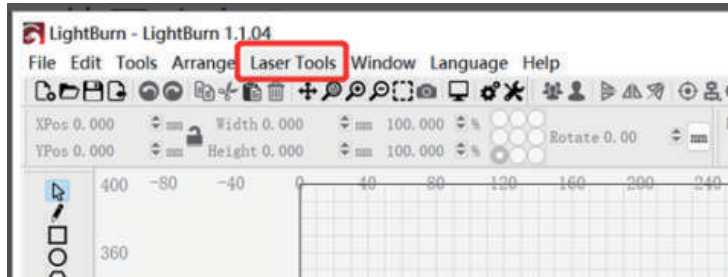

2.2 Set the correct parameters in the Rotary Setup window: As shown in the figure Steps:

- (1) Select the rotary type: Roller Type
- (2) Turn on "Enable Rotary"
- (3) Select the "Y Axis" rotary axis
- (4) Input the parameters (fixed value) of the rotary equipment
- (5) Enter the parameters of your engraved object: The actual measured diameter or circumference of the engraved object

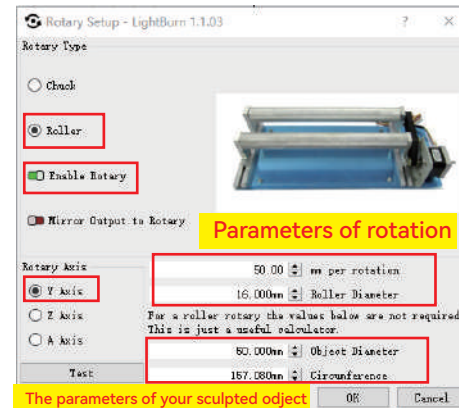



# Use LightBurn

3. Import the pattern you want to engrave, set the size of the pattern, and set the engraving power and speed.

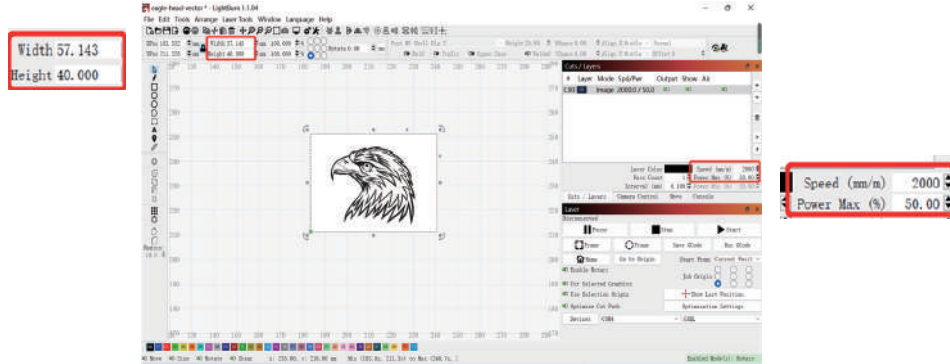

4. You can click "Frame" to preview the position of the pattern to be engraved, and then move the laser head to the expected position. It is recommended to use "Current Position" as the starting location, and click "Start" after completing the settings.

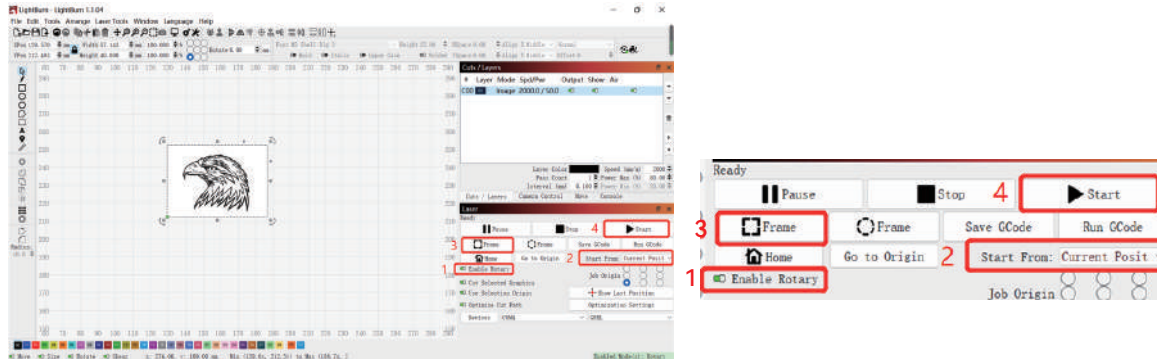

# **ATOMSTACK** MAKER

## **Customer service:**

For detailed warranty policy, please visit our official website: [www.atomstack.net](http://www.atomstack.net)  
For technical support and service, please email [support@atomstack.net](mailto:support@atomstack.net)

## **Manufacturer:**

Shenzhen AtomStack Technologies Co.,Ltd

## **Address:**

202, Building 1, Mingliang Technology Park, No. 88 Zhuguang North Road, Taoyuan Street, Nanshan District, Shenzhen, Guangdong, China

## **Scan QR code:**

QR code reader/barcode scanner or any app with a scanner



## R2 Roller Installationshandbuch

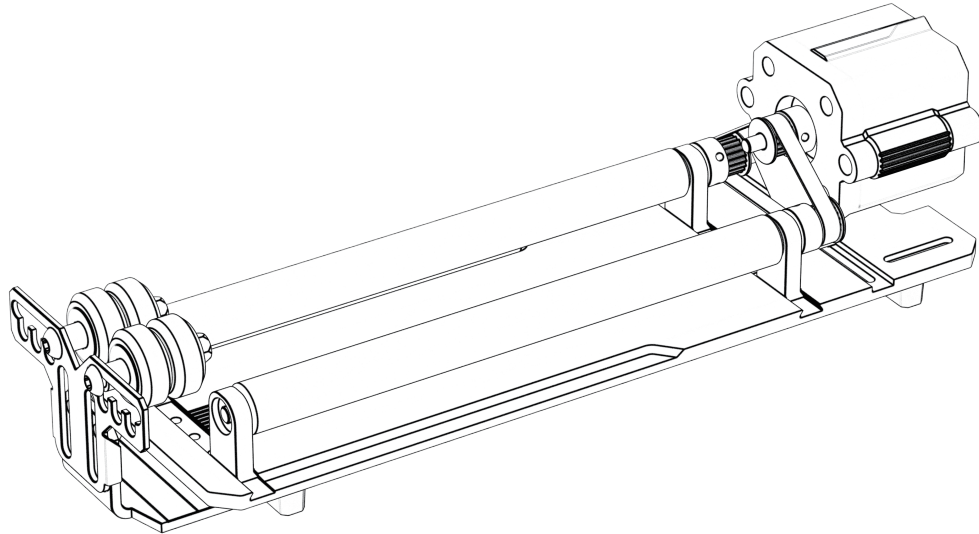

Hinweis: Das Bild ist nur als Referenz, vorbehaltlich der realen Sache.  
Bitte scannen Sie den zweidimensionalen Code für weitere Informationen.

F03-0136-0AA1  
Versions: A

# Packliste

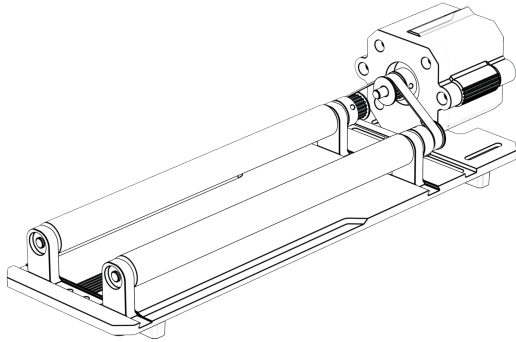

Rollenkörper\*1Pcs

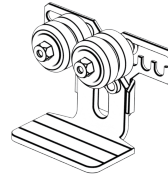

Halterung\*1Pcs



Erhöhte Füße \*4PCS



Sequenzlinie\*1Pcs



Linie in umgekehrter Reihenfolge\*1Pcs

# Installationsanleitung

## Schritt 1: Walze

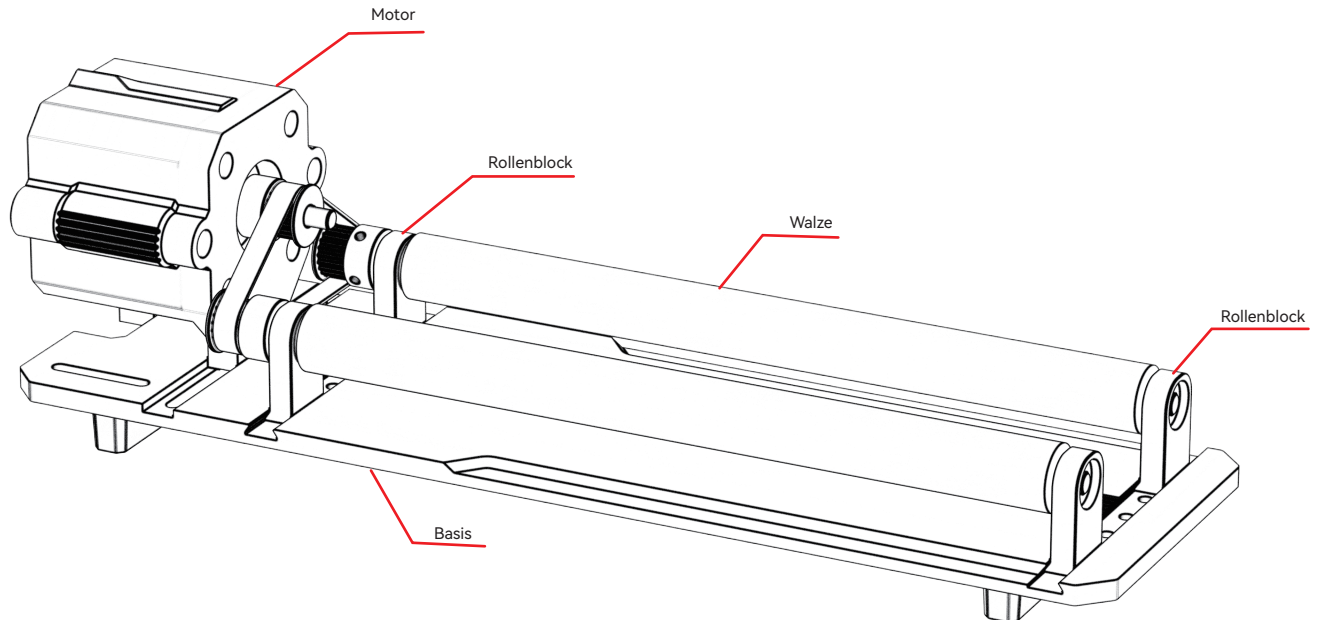

# Installationsanleitung

Schritt 2: Wählen Sie verschiedene Zahnräder aus, die Sie entsprechend den eingravierten Elementen einbauen

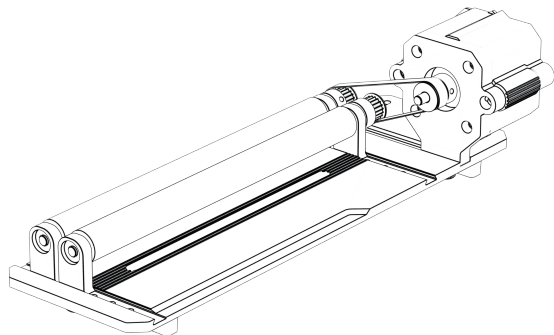

Getriebe 1:  $10\text{mm} \leq d \leq 20\text{mm}$

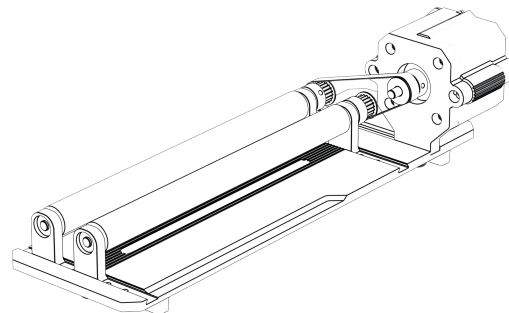

Getriebe 2:  $30\text{mm} \leq d \leq 40\text{mm}$

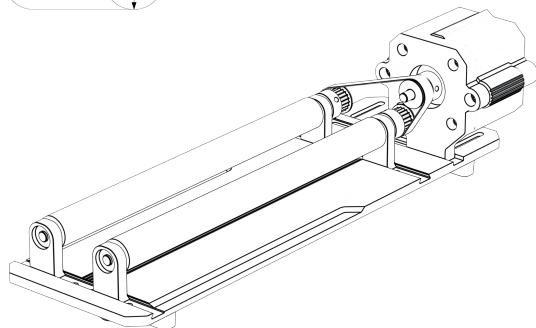

Getriebe 3:  $40\text{mm} \leq d \leq 50\text{mm}$

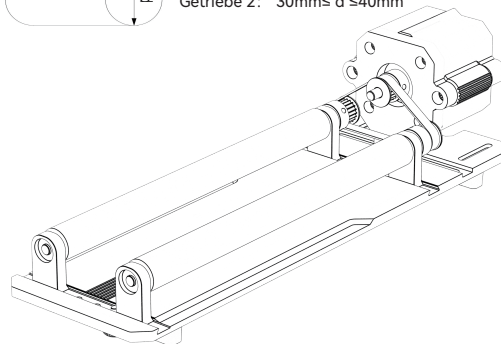

Getriebe 4:  $50\text{mm} \leq d \leq 80\text{mm}$

# Installationsanleitung

## Schritt 3: Gang einstellen

3.1 Wählen Sie verschiedene Gänge je nach den eingravierten Elementen.

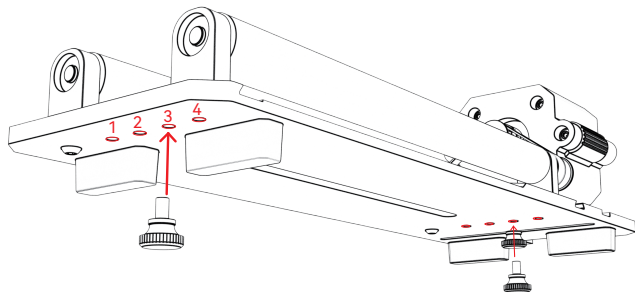

3.2 Bringen Sie die Rolle in den entsprechenden Gang und ziehen Sie die Schraube fest.

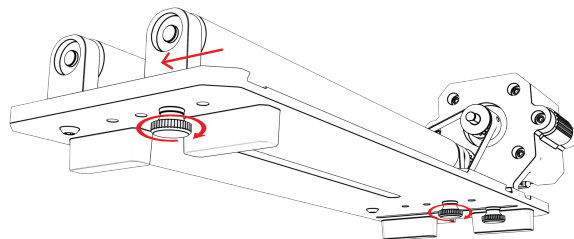

3.3 Bewegen Sie den Motor, um den Riemen zu spannen, und ziehen Sie die Schrauben an der Unterseite des Motors.

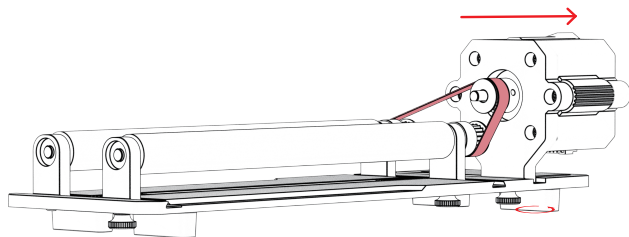

3.4 Einstellen der Halterung: Wählen Sie verschiedene Gänge entsprechend den eingravierten Sonderformen und bringen Sie die Halterung in eine geeignete Position.

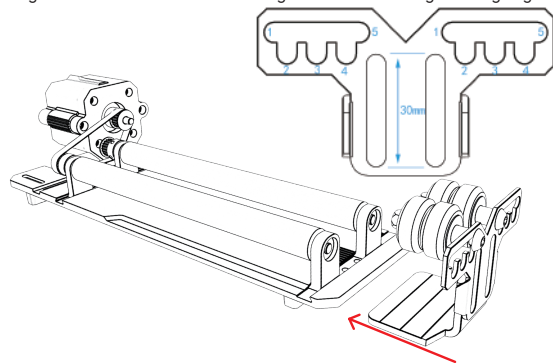

# Installationsanleitung

## Schritt 4: Verdrahtungsanweisungen

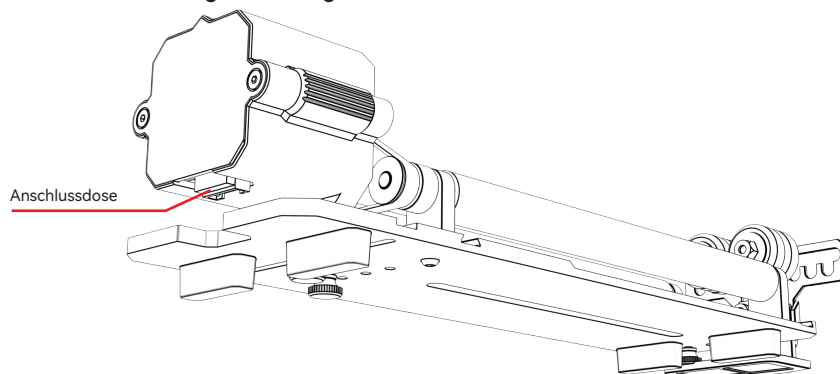

Kabelstecker Y-Achse Motor



Stecker des Futtermotors

Weißes Steckerkabel

Kabelstecker Y-Achse Motor

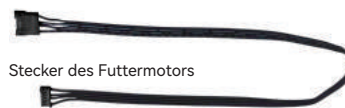

Stecker des Futtermotors

Schwarzes Zündkabel

Die Walze hat zwei Anschlussdrähte, den schwarzen Stecker und den weißen Stecker. Bitte beachten Sie, dass die Reihenfolge der Verdrahtung unterschiedlich ist und Sie sorgfältig anschließen müssen.

Der weiße 4-PIN-Stecker wird für den Anschluss der ATOMSTACK-Lasergraviermaschine verwendet.

Der schwarze 4PIN-Stecker wird für den Anschluss der Lasergravurmaschine eines anderen Herstellers verwendet.

Der Rollensatz unterstützt ATOMSTACK und Laserschneider und -gravierer von Drittanbietern. Sie müssen es an das Gerät anschließen und die entsprechende Software verwenden, um es zu bedienen. Wenn es nicht angeschlossen werden kann, ändern Sie bitte die Reihenfolge der Drähte, und der Änderungsprozess wird in Abbildung 1.1-1.2 gezeigt.

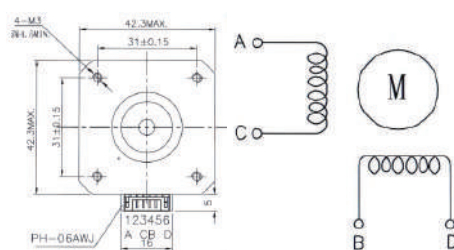

1.1 Anschlussreihenfolge des weißen Steckerkabels

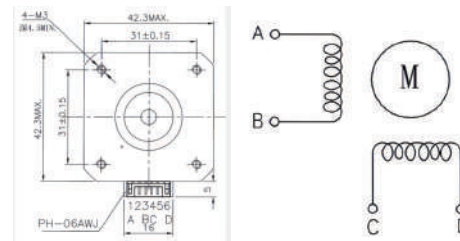

1.2 Anschlussreihenfolge des schwarzen Steckerkabels



# LightBurn verwenden

## 1. Hinzufügen von "Rotary aktivieren" zum Hauptfenster

1.1 Klicken Sie auf "Einstellungen" in der Symbolleiste.

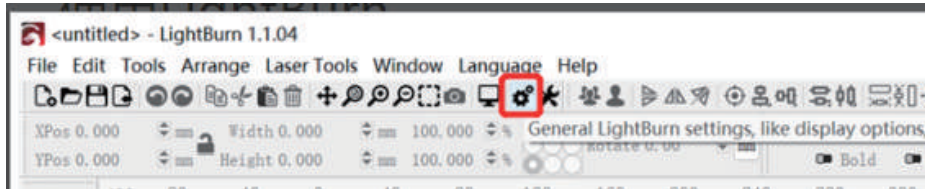

1.2 Aktivieren Sie im Einstellungsfenster die Schaltfläche "Drehfunktion im Hauptfenster anzeigen", und klicken Sie auf OK.

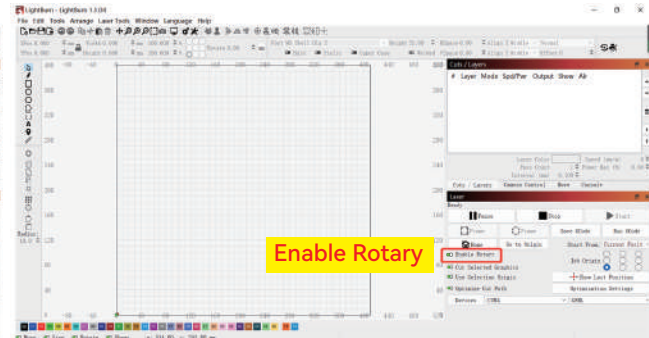
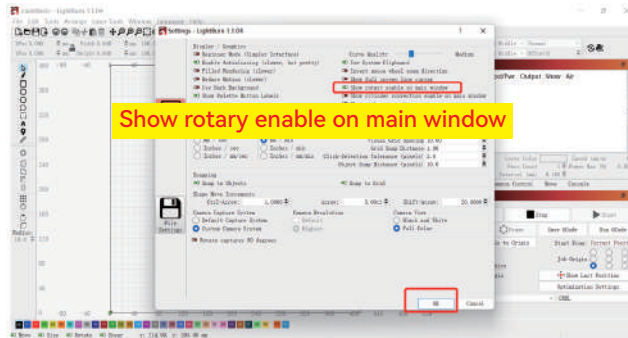

# LightBurn verwenden

## 2. Öffnen Sie das Fenster Rotary Setup und stellen Sie die Parameter ein

2.1 Öffnen Sie das Fenster "Rotary Setup": Klicken Sie auf "Laser Tools" in der Werkzeugleiste und dann auf "Rotary Setup".

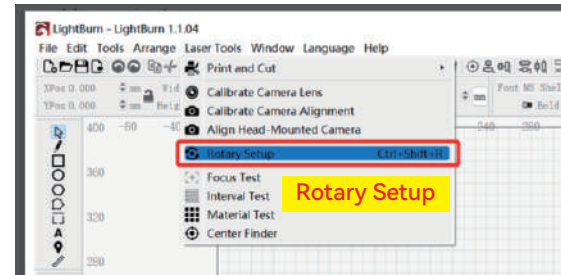
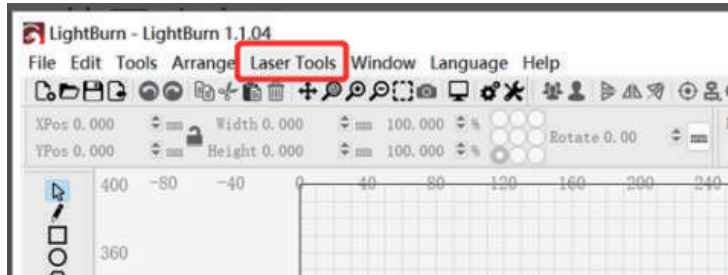

2.2 Stellen Sie die richtigen Parameter im Fenster Rotary Setup ein: Wie in der Abbildung gezeigt

Schritte:

- (1) Wählen Sie den Rotationstyp: Rollentyp
- (2) Schalten Sie "Rotation aktivieren" ein.
- (3) Wählen Sie die Drehachse "Y-Achse".
- (4) Geben Sie die Parameter (Festwert) der Drehvorrichtung ein
- (5) Geben Sie die Parameter Ihres gravierten Objekts ein: Der tatsächlich gemessene Durchmesser oder Umfang des gravierten Objekts

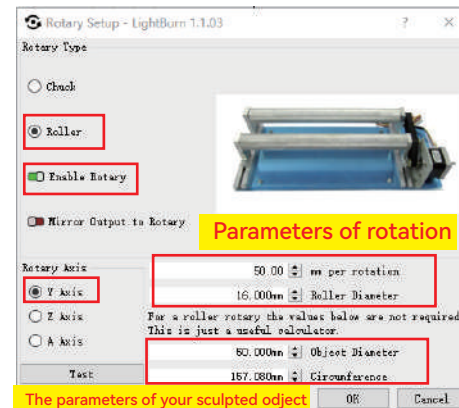

# LightBurn verwenden

3. Importieren Sie das Muster, das Sie gravieren möchten, legen Sie die Größe des Musters fest und stellen Sie die Gravurleistung und -geschwindigkeit ein.

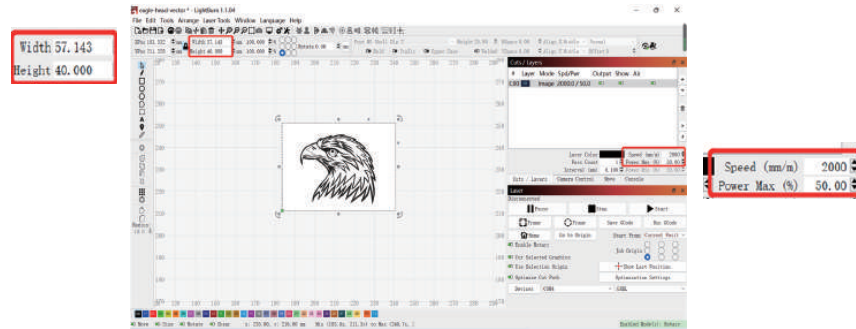

4. Sie können auf "Rahmen" klicken, um eine Vorschau der Position des zu gravierenden Musters anzuzeigen, und dann den Laserkopf an die erwartete Position bewegen. Es wird empfohlen, "Aktuelle Position" als Startposition zu verwenden und nach Abschluss der Einstellungen auf "Start" zu klicken.

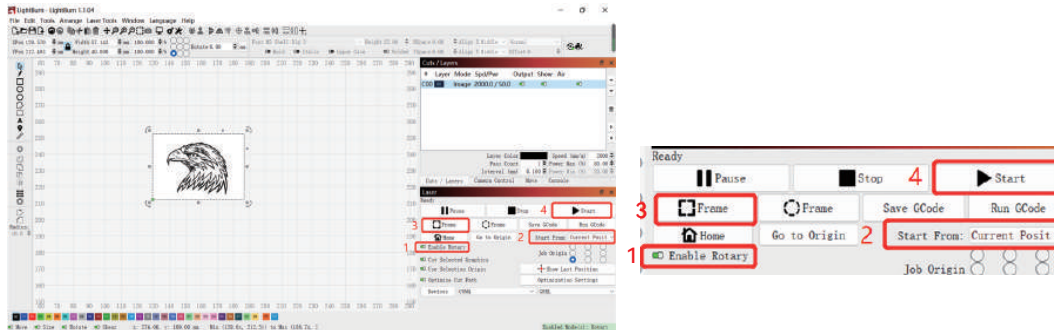

# ATOMSTACK MAKER

## Atención al cliente:

Ausführliche Informationen zur Garantie finden Sie auf unserer offiziellen Website: [www.atomstack.net](http://www.atomstack.net)

Für technische Unterstützung und Service, senden Sie bitte eine E-Mail an [support@atomstack.net](mailto:support@atomstack.net)

## Hersteller:

Shenzhen AtomStack Technologies Co.,Ltd

## Adresse:

202, Gebäude 1, Mingliang Technology Park, Nr. 88 Z Huguang North Road,  
Tao Yuan Street, n Anshan District, S very real, Gebäude G von GU Plan, China

## QR-Code scannen:

QR-Code-Leser/Barcode-Scanner oder eine beliebige App mit einem Scanner



## Manuel d'installation du R2 Roller

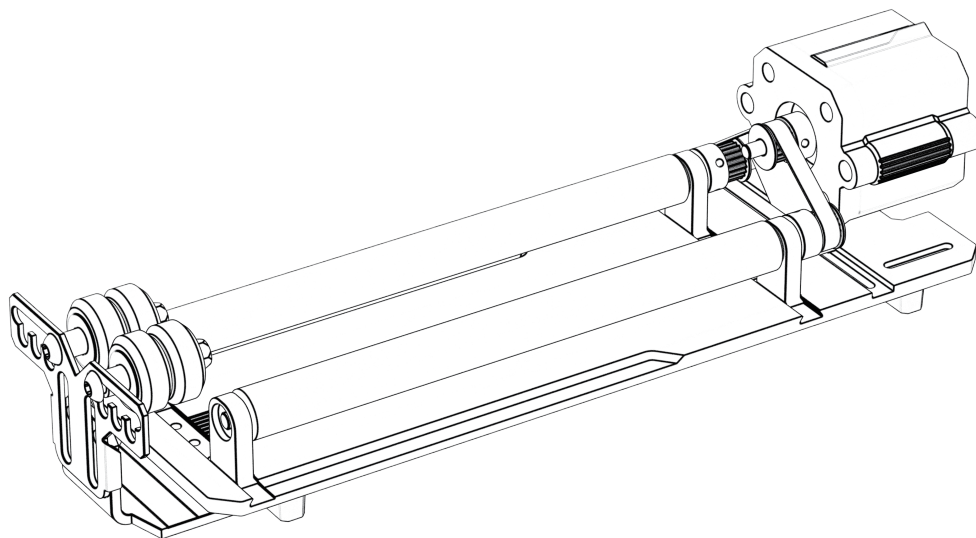

Note : L'image est pour référence seulement, sous réserve de la chose réelle. Veuillez scanner le code bidimensionnel pour plus d'informations.

# Liste de colisage

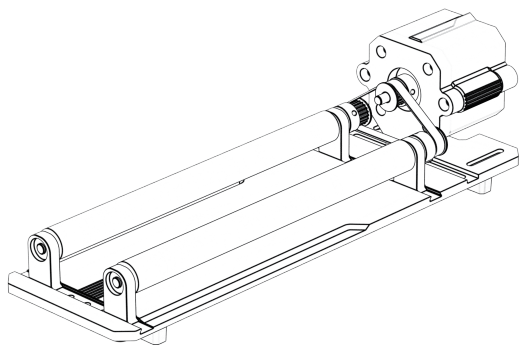

Corps du rouleau\*1Pcs

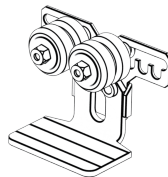

Console\*1Pcs

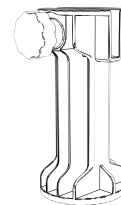

Pieds surélevés \* 4PCS



Ligne de séquence\*1Pcs



Ligne de séquence inversée\*1Pcs

# Guide d'installation

## Étape 1 : Rouleau

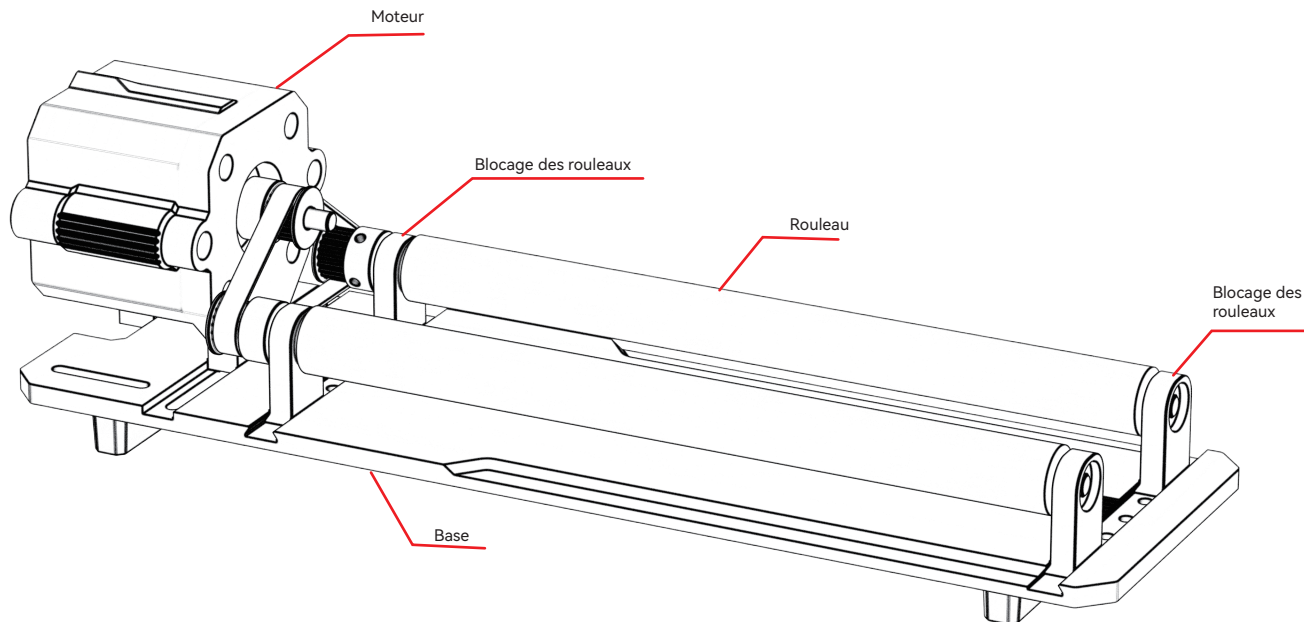

# Guide d'installation

Étape 2 : Choisissez les différents engrenages à installer en fonction des éléments gravés.

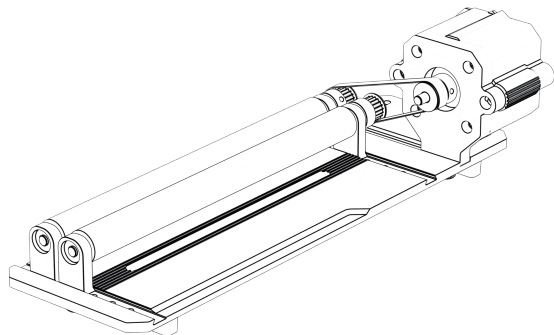

Engrenage 1:  $10\text{mm} \leq d \leq 20\text{mm}$

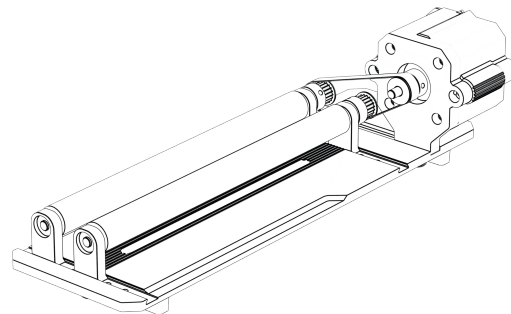

Engrenage 2:  $30\text{mm} \leq d \leq 40\text{mm}$

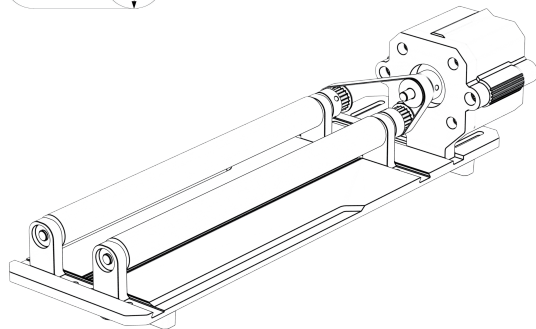

Engrenage 3:  $40\text{mm} \leq d \leq 50\text{mm}$

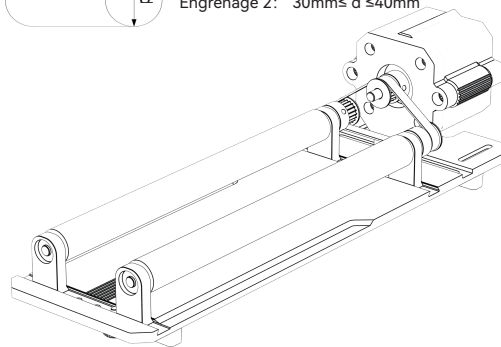

Engrenage 4:  $50\text{mm} \leq d \leq 80\text{mm}$



# Guide d'installation

## Étape 3 : Ajustement de la vitesse

3.1 Sélectionnez différents engrenages en fonction des éléments gravés.

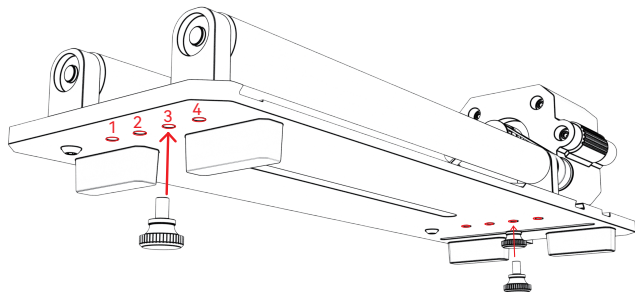

3.2 Déplacez le rouleau sur l'engrenage approprié et serrez la vis.

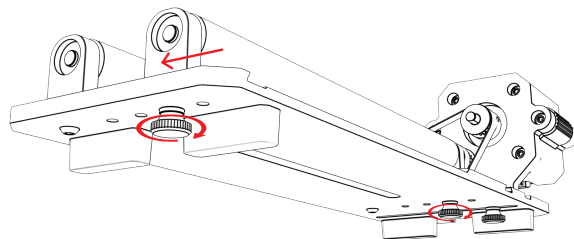

3.3 Déplacez le moteur pour tendre la courroie et serrez les vis au bas du moteur le bas du moteur.

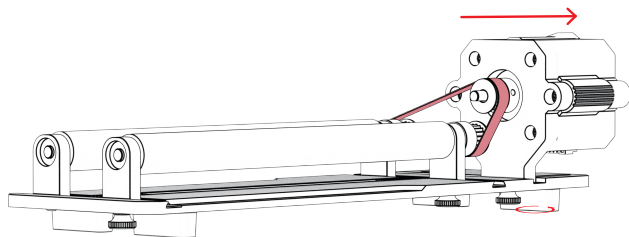

3.4 Ajustement de l'installation du support : choisissez différents engrenages en fonction des éléments gravés de forme spéciale, et déplacez le support à une position appropriée.

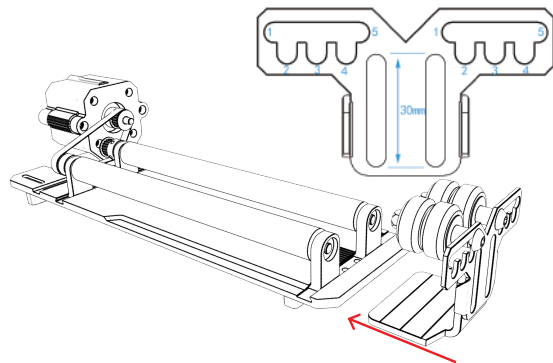

# Guide d'installation

## Étape 4 : Instructions de câblage

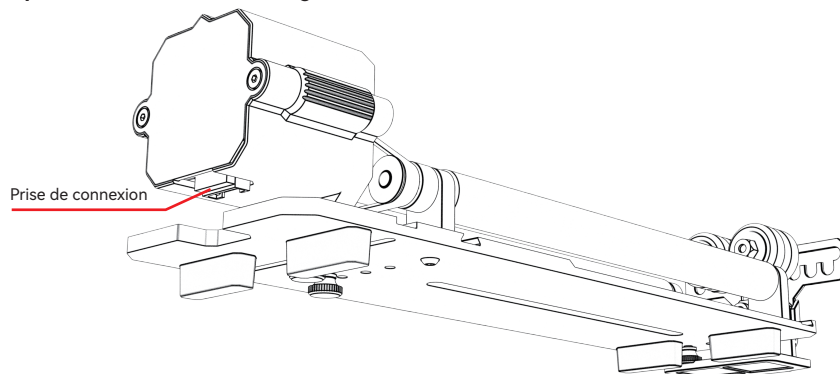

Fiche du câble du moteur de l'axe Y



Fiche du moteur du mandrin

Fil de bougie blanc

Fiche du câble du moteur de l'axe Y



Fiche du moteur du mandrin

Fil de bougie noir

Le rouleau a deux fils de connexion, la fiche noire et la fiche blanche, veuillez noter que leur séquence de câblage est différente et que vous devez les connecter soigneusement. Le fil de la fiche blanche 4PIN est utilisé pour connecter la machine de gravure laser ATOMSTACK.

La fiche noire à 4 broches est utilisée pour connecter la machine de gravure laser d'un autre fabricant.

Le kit de rouleaux est compatible avec les graveurs et les découpeurs laser d'ATOMSTACK et d'autres fabricants. Vous devez le connecter à l'appareil et utiliser le logiciel correspondant pour le faire fonctionner. S'il ne peut pas être connecté, veuillez modifier l'ordre des fils. Le processus de modification est illustré dans la figure 1.1-1.2.

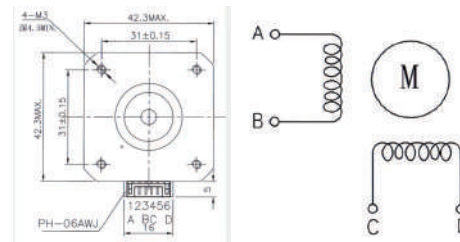
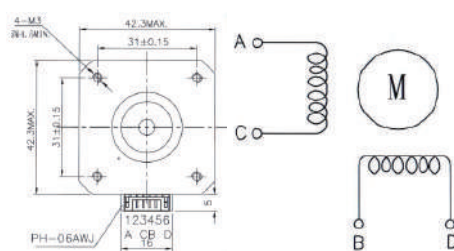

# Utilisez LightBurn

## 1. Ajouter "Activer le Rotary" à la fenêtre principale

1.1 Cliquez sur "Paramètres" dans la barre d'outils.

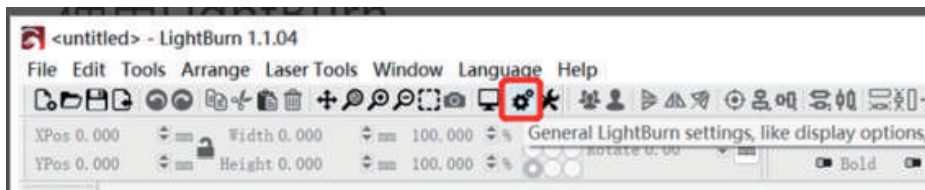

1.2 Dans la fenêtre des paramètres, activez le bouton "Afficher la possibilité de rotation sur la fenêtre principale", puis cliquez sur OK.

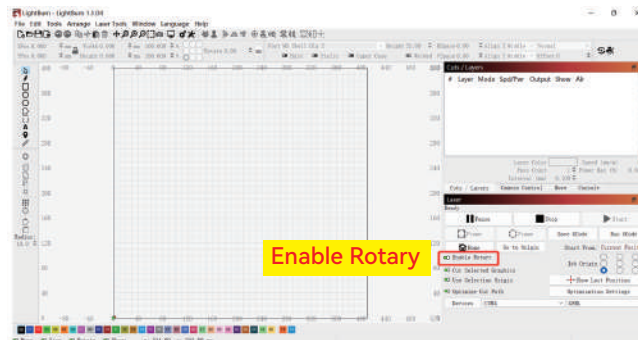
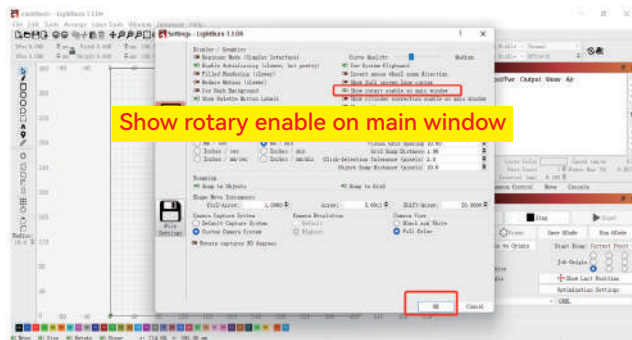

# Utilisez LightBurn

## 2. Ouvrez la fenêtre de configuration du Rotary et définissez les paramètres suivants

2.1 Ouvrez la fenêtre de configuration de la rotation : Cliquez sur "Laser Tools" dans la barre d'outils, puis sur "Rotary Setup".

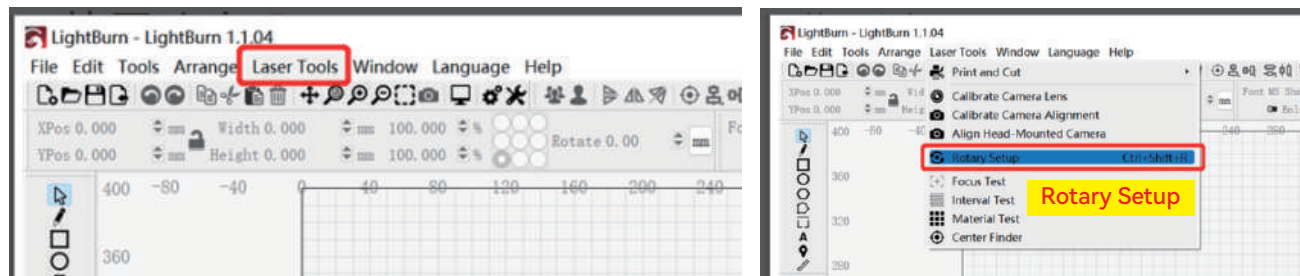

2.2 Réglez les paramètres corrects dans la fenêtre de configuration du Rotary :

Comme indiqué sur la figure

Étapes :

- (1) Sélectionnez le type de rotatif : Roller Type
- (2) Activez "Enable Rotary".
- (3) Sélectionnez l'axe rotatif "Y Axis".
- (4) Entrez les paramètres (valeur fixe) de l'équipement rotatif
- (5) Entrez les paramètres de votre objet gravé : Le diamètre ou la circonférence réelle mesurée de l'objet gravé.

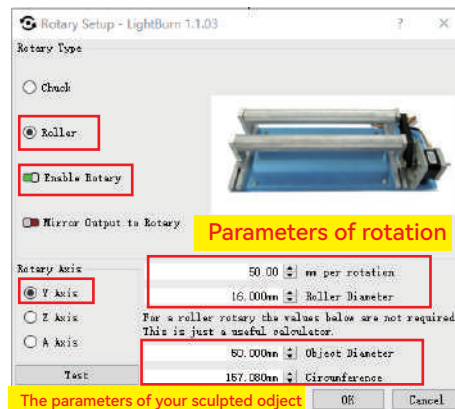

# Utilisez LightBurn

3. Importez le motif que vous souhaitez graver, définissez la taille du motif, puis réglez la puissance et la vitesse de gravure.

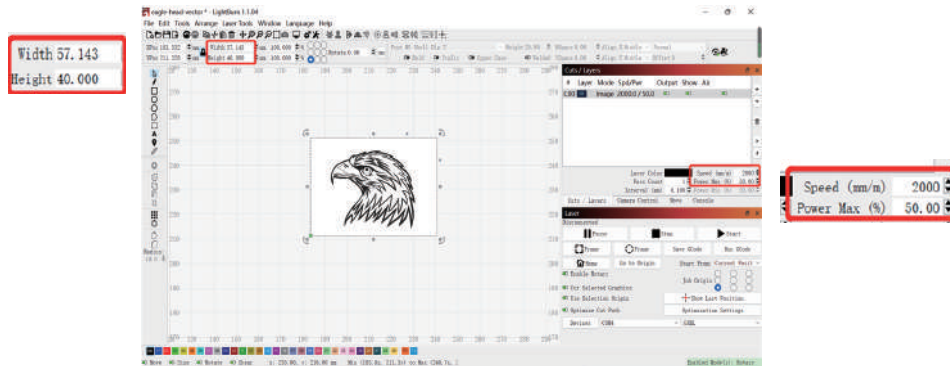

4. Vous pouvez cliquer sur "Frame" pour prévisualiser la position du motif à graver, puis déplacer la tête laser à la position prévue. Il est recommandé d'utiliser "Current Position" comme position de départ et de cliquer sur "Start" après avoir terminé les réglages.

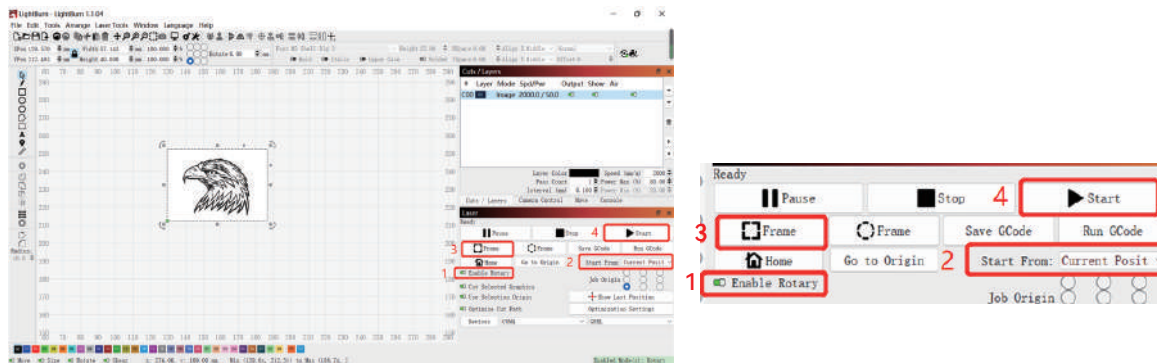

# ATOMSTACK MAKER

## Service clientèle :

Pour une politique de garantie détaillée, veuillez consulter notre site officiel : [www.atomstack.net](http://www.atomstack.net)

Pour le soutien technique et le service, veuillez envoyer un courriel à [support@atomstack.net](mailto:support@atomstack.net)

## Fabricant :

Shenzhen AtomStack Technologies Co.,Ltd

## Adresse :

202, bâtiment 1, parc technologique de Mingliang, n° 88 Z route nord de Huguang, rue tao yuan, district de n Anshan, S très réel, bâtiment G du plan GU, Chine

## Scanner le code QR :

Lecteur de code QR/numériseur de codes-barres ou toute application avec un numériseur.



## Manuale di installazione del rullo R2 Roller

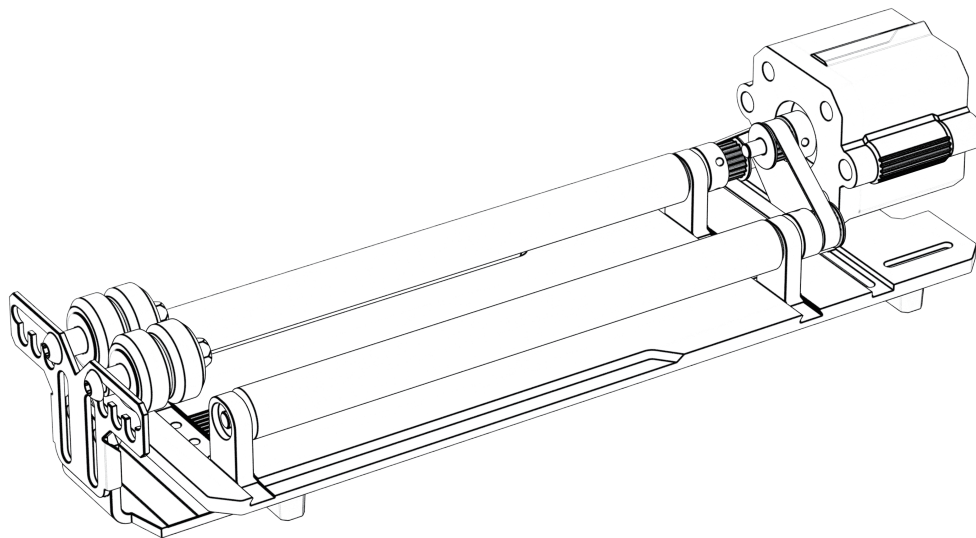

Nota: l'immagine è solo per riferimento, soggetto alla cosa reale. Per maggiori informazioni, scansionare il codice bidimensionale.

F03-0136-0AA1  
Versions: A

# Lista di imballaggio

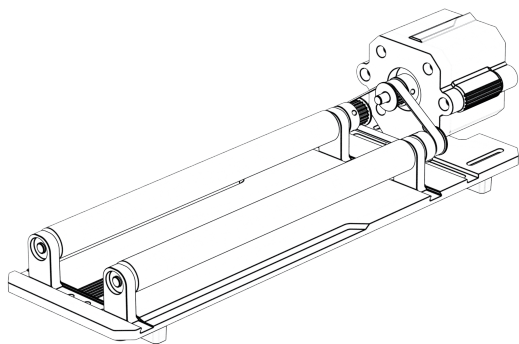

Corpo del rullo\*1Pcs

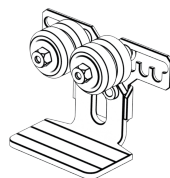

Staffa\*1Pcs

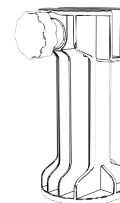

Piedi rialzati \*4PCS



Linea di sequenza\*1Pcs



Linea di sequenza inversa\*1Pcs



# Guida all'installazione

## Fase 1: rullo

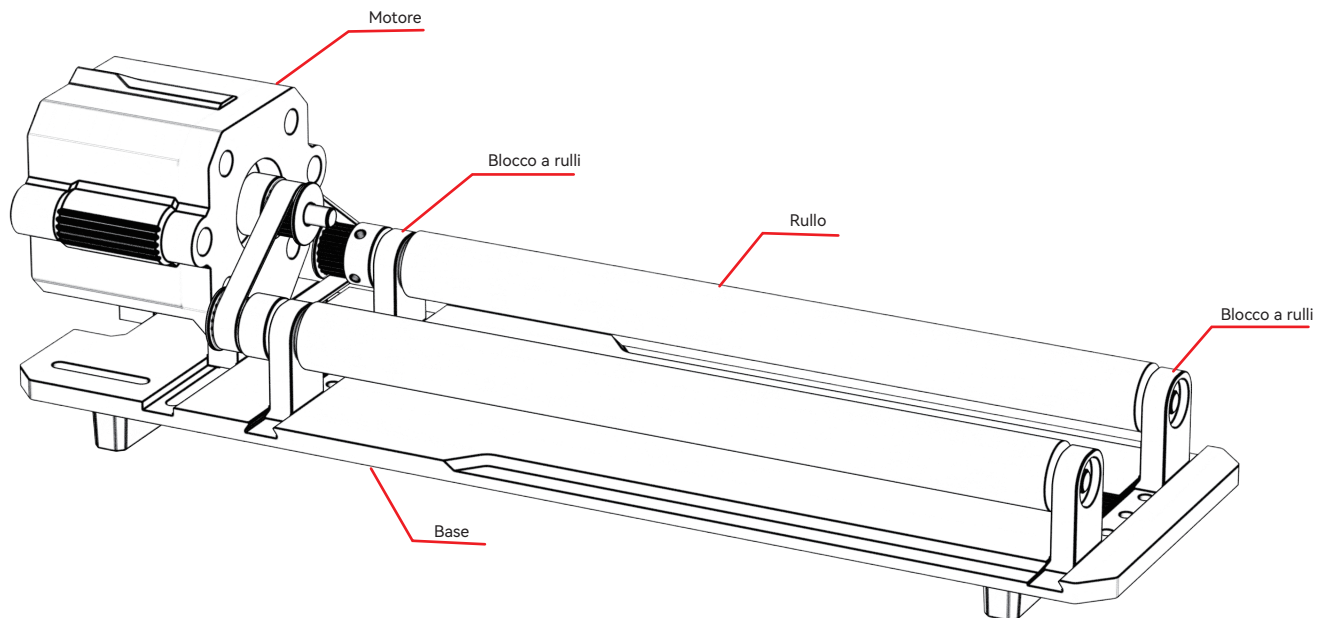

# Guida all'installazione

Fase 2: scegliere diversi ingranaggi da installare in base agli elementi incisi

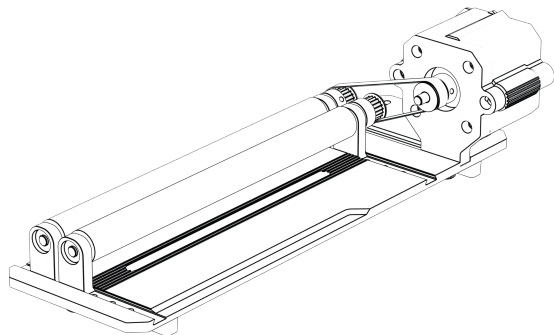

Ingranaggio 1:  $10\text{mm} \leq d \leq 20\text{mm}$

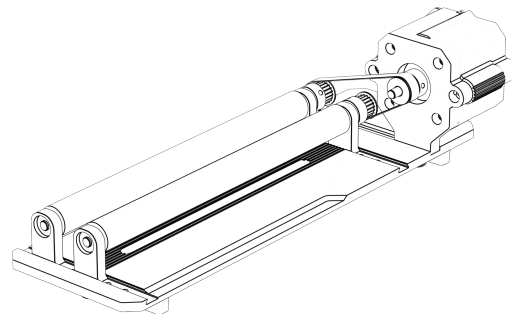

Ingranaggio 2:  $30\text{mm} \leq d \leq 40\text{mm}$

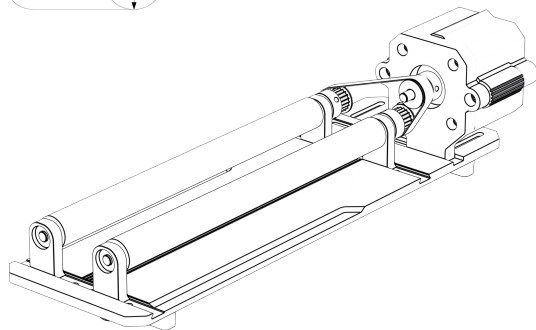

Ingranaggio 3:  $40\text{mm} \leq d \leq 50\text{mm}$

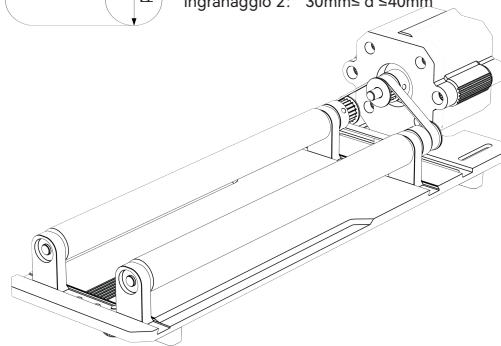

Ingranaggio 4:  $50\text{mm} \leq d \leq 80\text{mm}$

# Guida all'installazione

## Fase 3: Regolazione della marcia

3.1 Selezionare diversi ingranaggi in base agli elementi incisi.

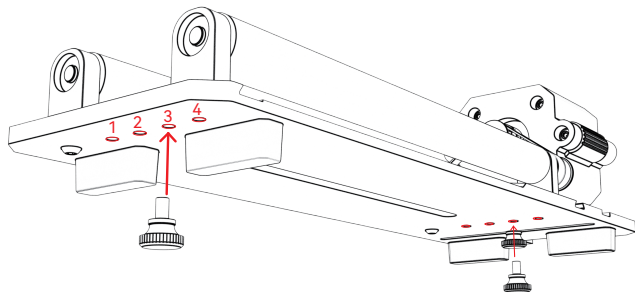

3.2 Spostare il rullo sull'ingranaggio appropriato e serrare la vite.

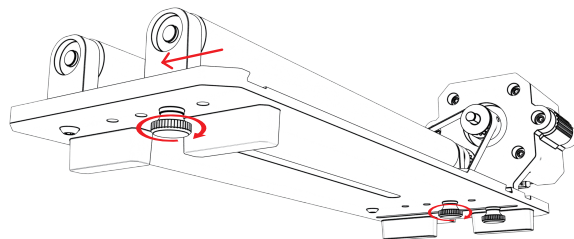

3.3 Spostare il motore per tendere la cinghia e stringere le viti nella parte inferiore del motore. alla base del motore.

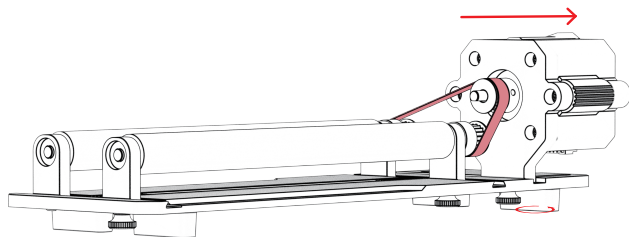

3.4 Regolazione dell'installazione della staffa: scegliere diversi ingranaggi in base agli elementi di forma speciale incisi e spostare la staffa in una posizione adeguata.

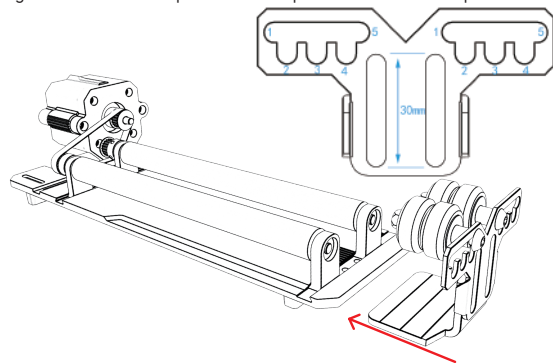

# Guida all'installazione

## Passo 4: Istruzioni per il cablaggio

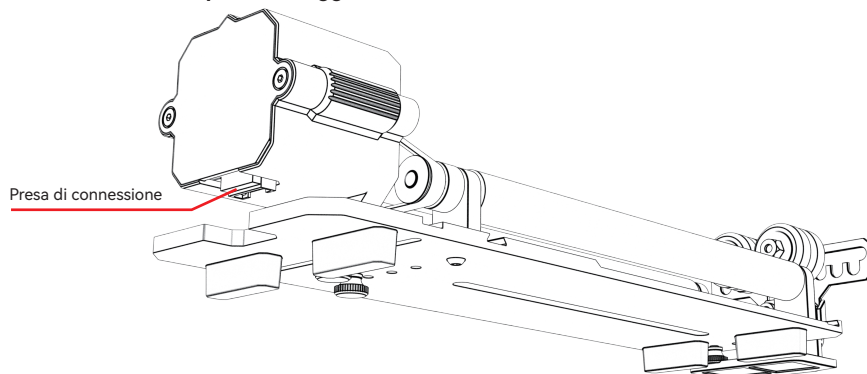

Connettore del cavo del motore dell'asse Y



Spina del motore del mandrino

Filo della spina bianco

Connettore del cavo del motore dell'asse Y

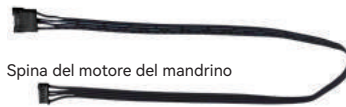

Spina del motore del mandrino

Filo della spina nero

Il rullo è dotato di due fili di collegamento, la spina nera e la spina bianca; si prega di notare che la sequenza di cablaggio è diversa ed è necessario collegarla con attenzione. Il filo bianco a 4 pin è utilizzato per collegare la macchina per incisione laser ATOMSTACK.

Il filo della spina nera a 4 pin è utilizzato per collegare la macchina per incisione laser di terzi.

Il kit di rulli supporta ATOMSTACK e tagliatori e incisor laser di terze parti. È necessario collegarlo al dispositivo e utilizzare il software corrispondente per utilizzarlo. Se non è possibile collegarlo, cambiare l'ordine dei fili; la procedura di modifica è illustrata nella Figura 1.1-1.2.

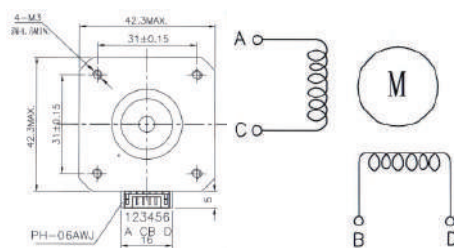

1.1 Sequenza di collegamento del filo bianco della spina

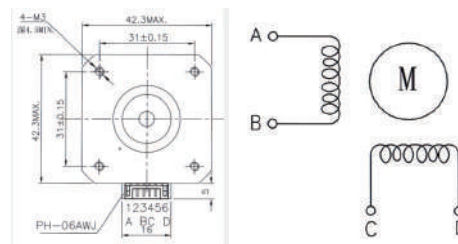

1.2 Sequenza di collegamento del filo nero della spina

# Utilizzare LightBurn

## 1. Aggiungere "Abilita rotazione" alla finestra principale

1.1 Fare clic su "Impostazioni" nella barra degli strumenti.

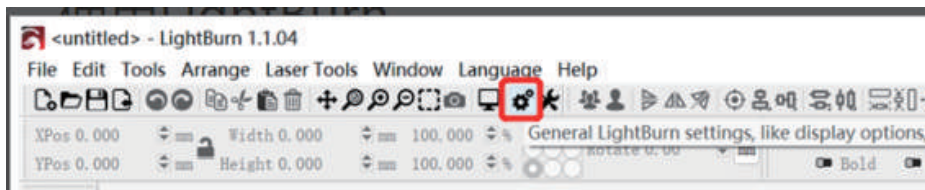

1.2 Nella finestra delle impostazioni, attivare il pulsante "Mostra abilitazione rotazione nella finestra principale" e fare clic su OK.

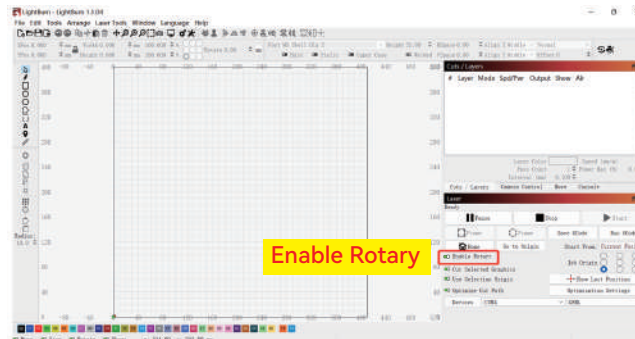
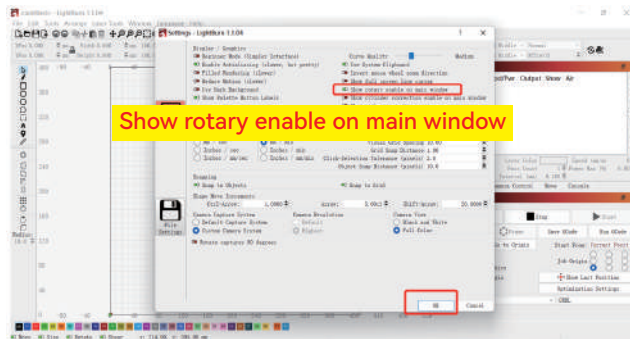

# Utilizzare LightBurn

## 2. Aprire la finestra Impostazione rotante e impostare i parametri

2.1 Aprire la finestra Impostazione rotativa: Fare clic su "Strumenti laser" nella barra degli strumenti e quindi su "Impostazione rotativa".

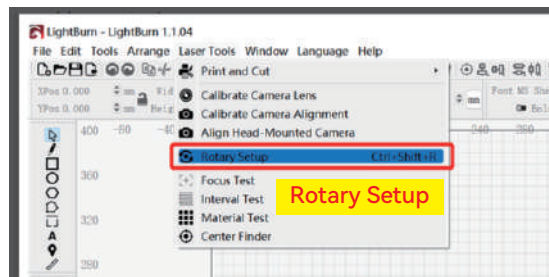
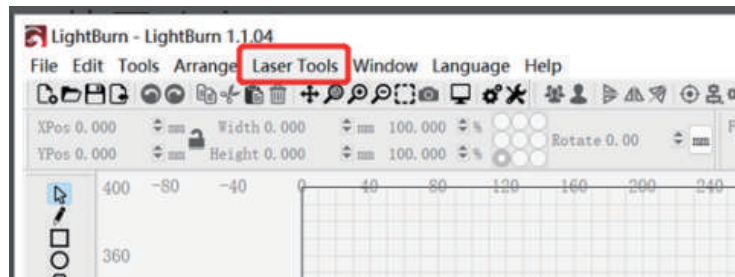

2.2 Impostare i parametri corretti nella finestra Rotary Setup: Come mostrato nella figura

Passi:

- (1) Selezionare il tipo di rotante: Tipo di rullo
- (2) Attivare "Abilita rotazione".
- (3) Selezionare l'asse rotante "Asse Y".
- (4) Inserire i parametri (valore fisso) dell'apparecchiatura rotante
- (5) Inserire i parametri dell'oggetto inciso: Il diametro effettivo misurato o la circonferenza dell'oggetto inciso

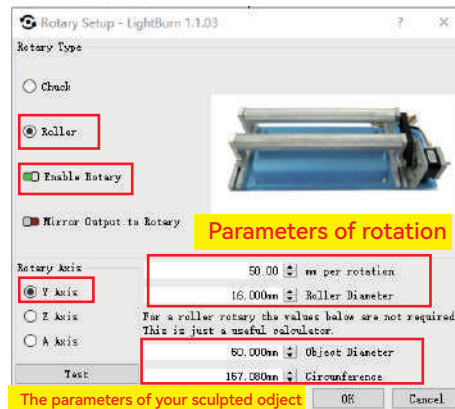

# Utilizzare LightBurn

3. Importare il modello che si desidera incidere, impostare le dimensioni del modello e la potenza e la velocità di incisione.

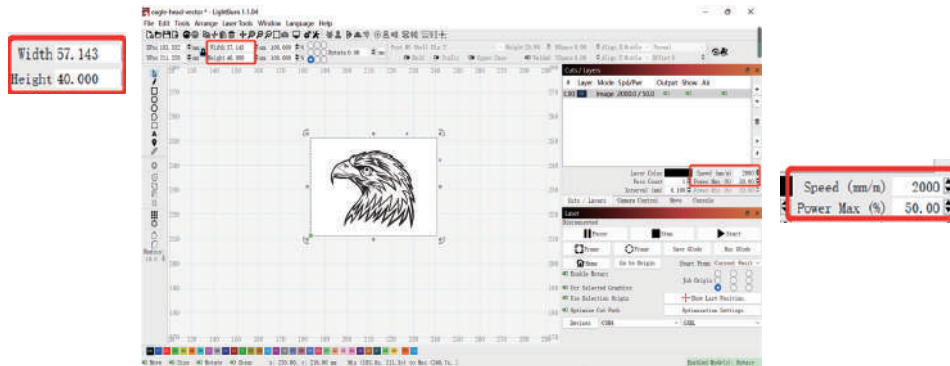

4. È possibile fare clic su "Cornice" per visualizzare l'anteprima della posizione del modello da incidere, quindi spostare la testa laser nella posizione prevista. Si consiglia di utilizzare "Posizione corrente" come posizione iniziale e di fare clic su "Avvia" dopo aver completato le impostazioni.

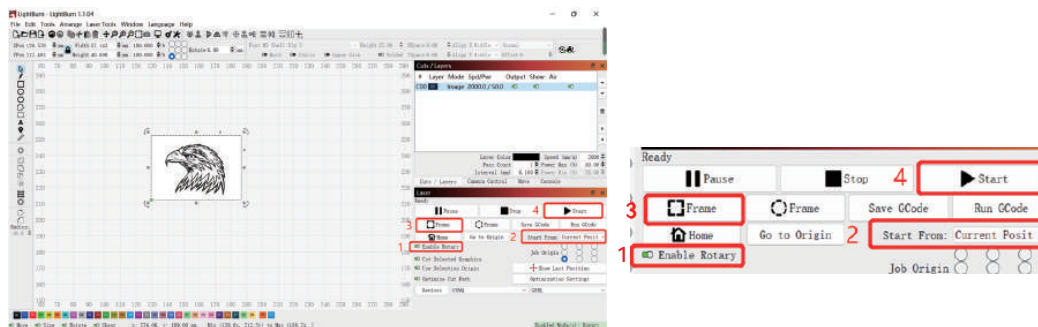

# ATOMSTACK MAKER

## Servizio clienti:

Per una politica di garanzia dettagliata, si prega di visitare il nostro sito ufficiale: [www.atomstack.net](http://www.atomstack.net)

Per il supporto tecnico e l'assistenza, inviare un'e-mail a [support@atomstack.net](mailto:support@atomstack.net)

## Produttore:

Shenzhen AtomStack Technologies Co.,Ltd

## Indirizzo:

202, edificio 1, parco tecnologico Mingliang, n. 88 Z Huguang north road, via tao yuan, distretto di Anshan, S molto reale, edificio G del piano GU, Cina

## Scansione del codice QR:

Letture di codici QR/scanner di codici a barre o qualsiasi app dotata di scanner





## Manual de instalación del rodillo R2 Roller

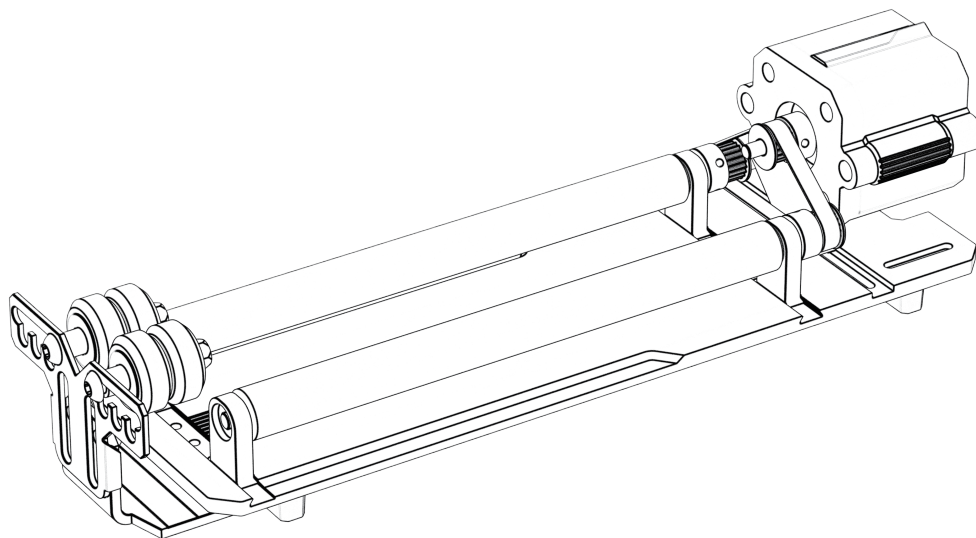

Nota: La imagen es sólo para referencia, sujeto a la cosa real. Por favor, escanee el código bidimensional para obtener más información.

# Lista de embalaje

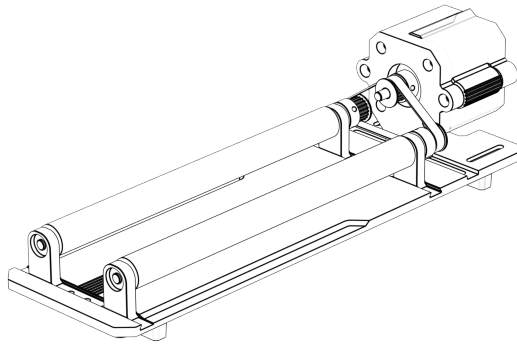

Cuerpo del rodillo\*1Pcs

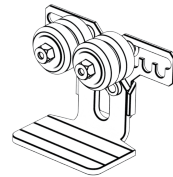

Soporte\*1Pcs



pies elevados \*4PCS



Línea de secuencia\*1Pcs



Línea de secuencia inversa\*1Pcs

# Guía de instalación

## Paso 1: Rodillo

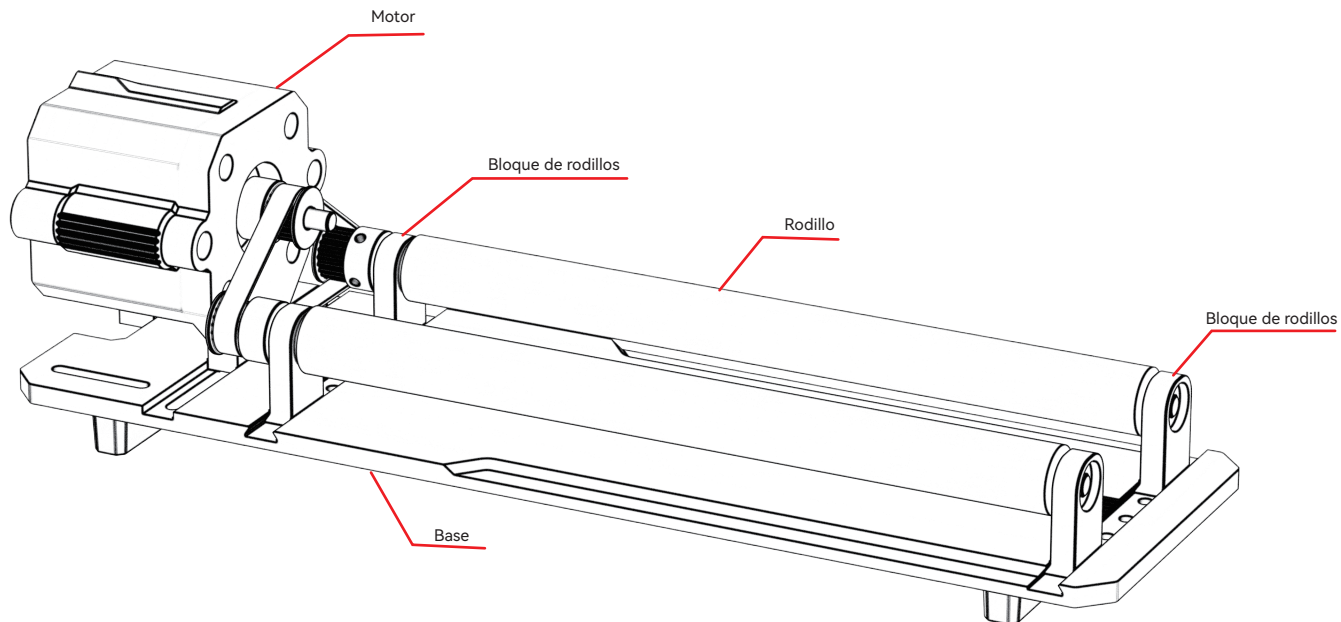

# Guía de instalación

Paso 2: Elegir diferentes marchas para instalar según los elementos grabados

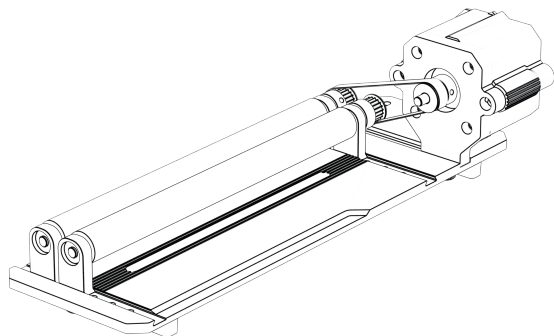

Engranaje 1: 10mm  $\leq$  d  $\leq$  20mm

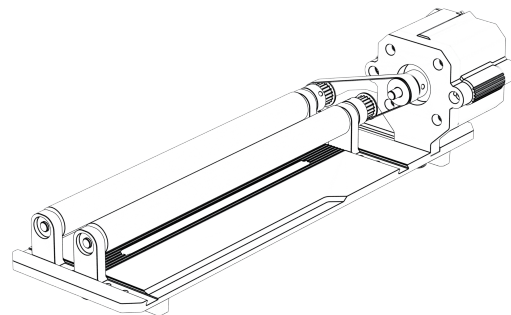

Engranaje 2: 30mm  $\leq$  d  $\leq$  40mm

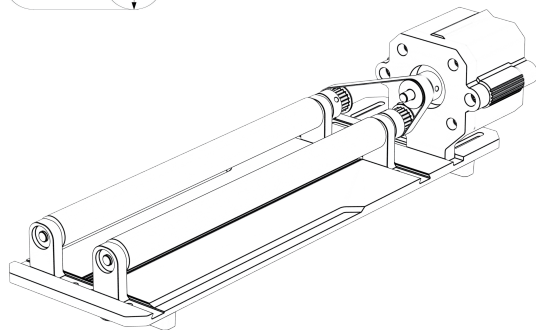

Engranaje 3: 40mm  $\leq$  d  $\leq$  50mm

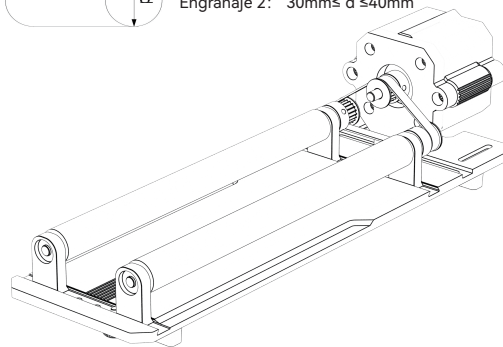

Engranaje 4: 50mm  $\leq$  d  $\leq$  80mm

# Guía de instalación

## Paso 3: Ajustar la marcha

3.1 Seleccione diferentes marchas en función de los elementos grabados.

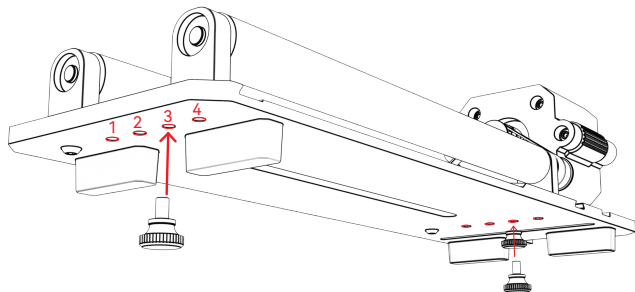

3.2 Coloque el rodillo en la marcha adecuada y apriete el tornillo.

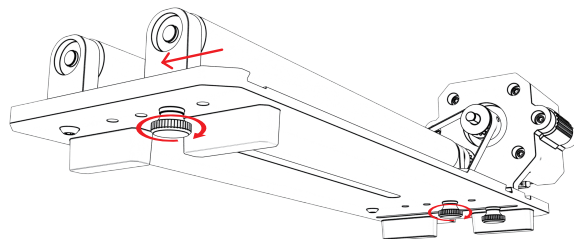

3.3 Mueva el motor para tensar la correa y apriete los tornillos en la parte inferior del motor.

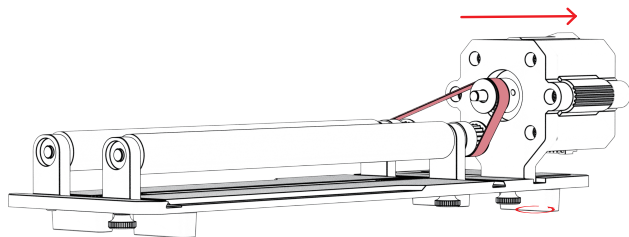

3.4 Ajuste de la instalación del soporte: elija diferentes marchas de acuerdo con los elementos grabados de forma especial, y mueva el soporte a una posición adecuada.

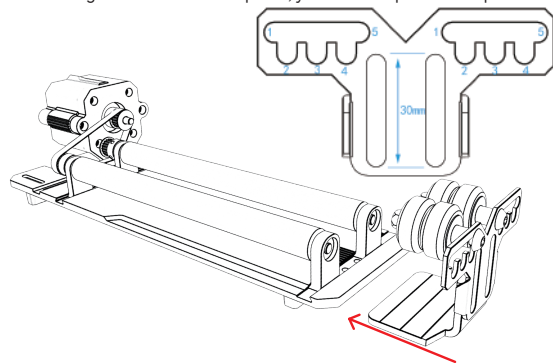

# Guía de instalación

## Paso 4: Instrucciones de cableado

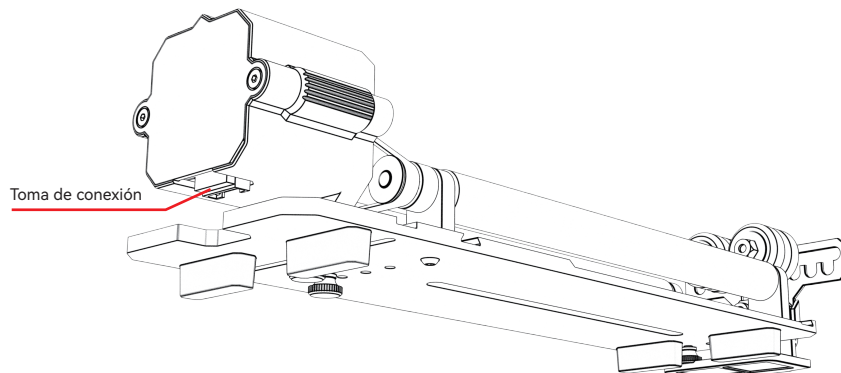

Enchufe del cable del motor del eje Y



Enchufe del motor del mandril

Cable de bujía blanco

Enchufe del cable del motor del eje Y

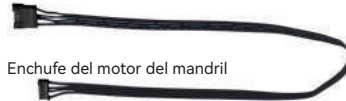

Enchufe del motor del mandril

Cable de bujía negro

El rodillo tiene dos cables de conexión, el enchufe negro y el enchufe blanco, tenga en cuenta que su secuencia de cableado es diferente y hay que conectar con cuidado.

El cable blanco de 4PIN se utiliza para conectar la máquina de grabado láser ATOMSTACK.

El cable negro de 4PIN se utiliza para conectar la máquina de grabado láser de terceros.

El kit de rodillos soporta ATOMSTACK y cortadoras y grabadoras láser de terceros. Es necesario conectarlo al dispositivo y utilizar el software correspondiente para hacerlo funcionar. Si no se puede conectar, por favor cambie el orden de los cables, y el proceso de cambio se muestra en la Figura 1.1-1.2.

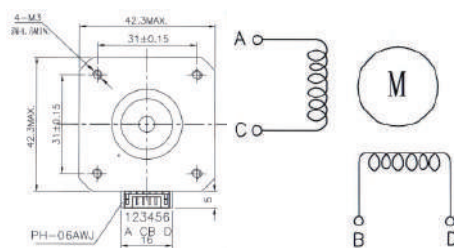

1.1 Secuencia de conexión del cable blanco de la clavija

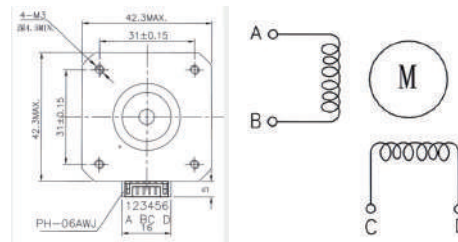

1.2 Secuencia de conexión del cable negro de la bujía

# Utilice LightBurn

## 1. Añadir "Activar Rotary" a la ventana principal

1.1 Haga clic en "Configuración" en la barra de herramientas

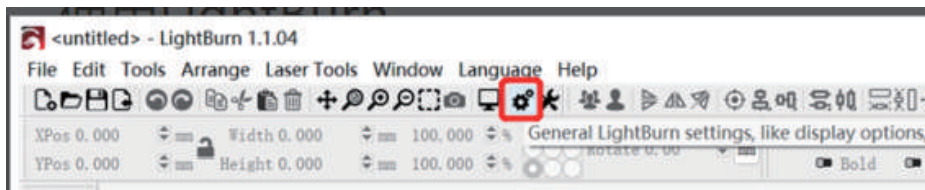

1.2 En la ventana de configuración, activa el botón "Mostrar activación de giro en la ventana principal" y haz clic en Aceptar.

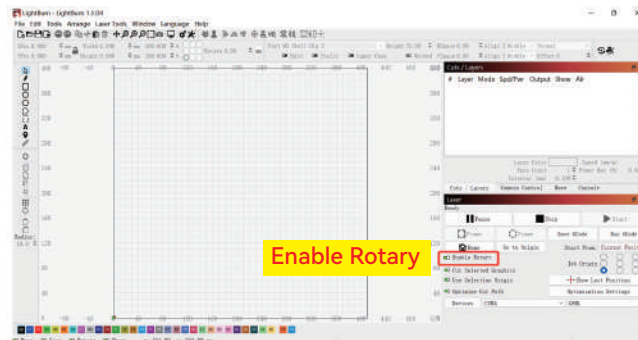
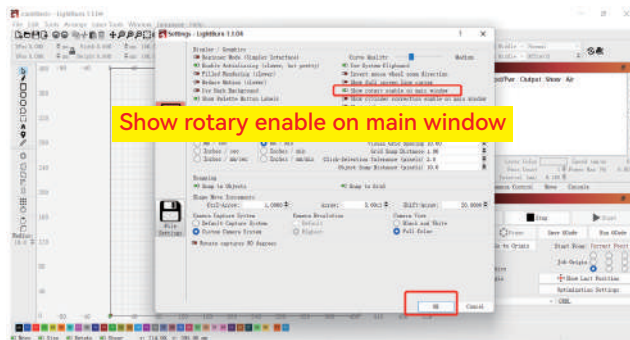

# Utilice LightBurn

## 2. Abra la ventana Configuración de Rotary y ajuste los parámetros

2.1 Abra la ventana "Rotary Setup": Haga clic en "Laser Tools" en la barra de herramientas y luego en "Rotary Setup"

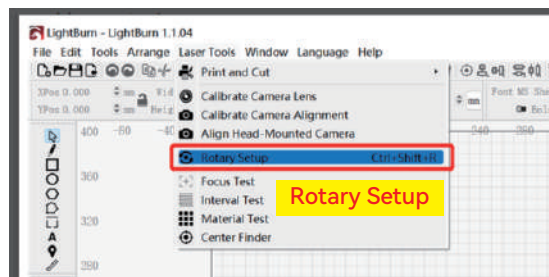
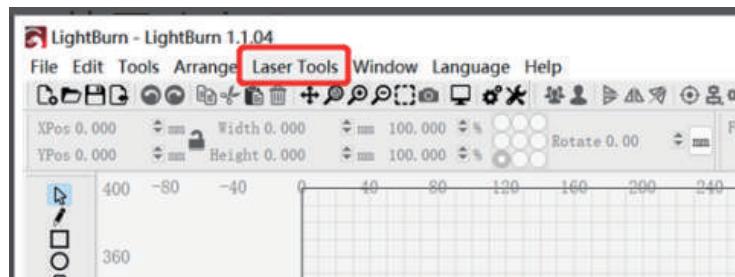

2.2 Establezca los parámetros correctos en la ventana Configuración de Rotary:

Como se muestra en la figura

Pasos a seguir:

- (1) Seleccione el tipo rotativo: Tipo de Rodillo
- (2) Activar "Enable Rotary" (Activar Rotativo)
- (3) Seleccionar el eje rotativo "Y Axis"
- (4) Introduzca los parámetros (valor fijo) del equipo rotativo
- (5) Introduzca los parámetros de su objeto grabado: El diámetro o circunferencia real medido del objeto grabado

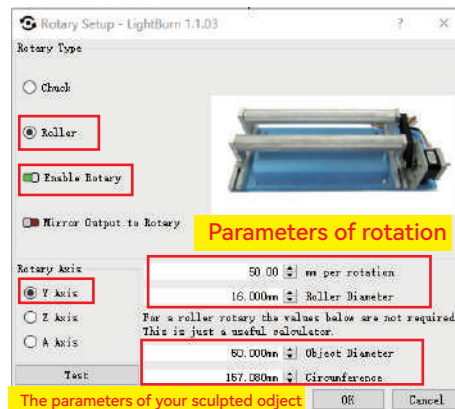



# Utilice LightBurn

3. Importa el patrón que deseas grabar, ajusta el tamaño del patrón y configura la potencia y la velocidad de grabado.

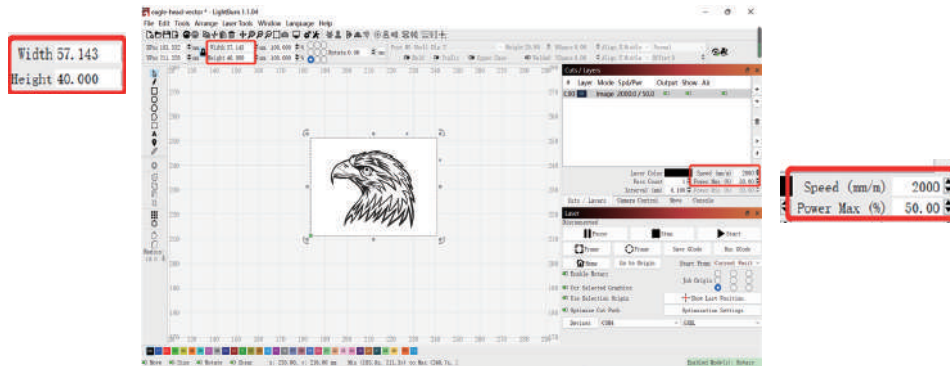

4. Puede hacer clic en "Encuadre" para previsualizar la posición del patrón a grabar y, a continuación, mover el cabezal láser a la posición esperada. Se recomienda utilizar "Posición actual" como ubicación inicial, y hacer clic en "Inicio" una vez completados los ajustes.

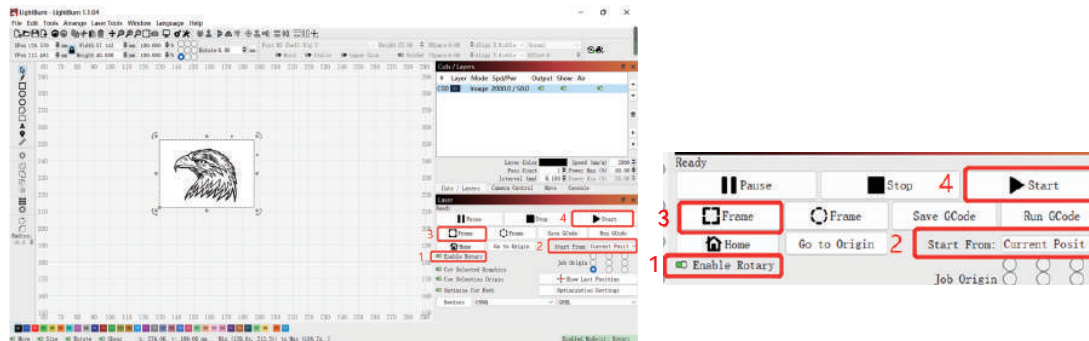

# ATOMSTACK MAKER

## Atención al cliente:

Para obtener información detallada sobre la política de garantía, visite nuestro sitio web oficial: [www.atomstack.net](http://www.atomstack.net)

Para asistencia técnica y servicio, envíe un correo electrónico a [support@atomstack.net](mailto:support@atomstack.net)

## Fabricante:

Shenzhen AtomStack Technologies S.L

## Dirección:

202, edificio 1, parque tecnológico Mingliang, no. 88 Z Huguang North Road, calle Tao Yuan, distrito n de Anshan, S muy real, edificio G del plan GU, China

## Escanea el código QR:

Lector de códigos QR/escáner de códigos de barras o cualquier aplicación con escáner

